



GOVERNMENT OF TAMIL NADU

# STANDARD SEVEN

TERM - II

VOLUME - 3

# SCIENCE SOCIAL SCIENCE

A publication under Free Textbook Programme of Government of Tamil Nadu

Department of School Education

**Untouchability is Inhuman and a Crime**

## Government of Tamil Nadu

First Edition - 2019

(Published under New Syllabus in  
Trimester Pattern)

**NOT FOR SALE**

### Content Creation



State Council of Educational Research  
and Training

© SCERT 2019

### Printing & Publishing



Tamil Nadu Textbook and Educational  
Services Corporation

[www.textbooksonline.tn.nic.in](http://www.textbooksonline.tn.nic.in)



## PREFACE

The Science textbook for standard Seven has been prepared following the guidelines given in the National Curriculum Framework 2005. The book enables the reader to read the text, comprehend and perform the learning experiences with the help of teacher. The Students explore the concepts through activities and by the teacher demonstration. Thus the book is learner centric with simple activities that can be performed by the students under the supervision of teachers.

## HOW TO USE THE BOOK?

- ❖ The Second term VII Science book has six units.
- ❖ Two units planned for every month including computer science chapter has been introduced.
- ❖ Each unit comprises of simple activities and experiments that can be done by the teacher through demonstration if necessary student's can perform them.
- ❖ Colorful info-graphics and info-bits enhance the visual learning.
- ❖ Glossary has been introduced to learn scientific terms.
- ❖ The "Do you know?" box can be used to enrich the knowledge of general science around the world.
- ❖ ICT Corner and QR code has been introduced in each unit for the first time to enhance digital science skills.

### Lets use the QR code in the text books ! How ?

- ❖ Download the QR code scanner from the Google play store/ Apple App Store into your Smart phone.
- ❖ Open the QR code scanner application
- ❖ Once the scanner button in the application is clicked, camera opens and then bring it closer to the QR code in the text book.
- ❖ Once the camera detects the QR code, a URL appears in the screen.
- ❖ Click the URL and go to the content page.





## Table of Contents

<b>Unit 1</b>	<b>Heat and Temperature .....</b>	<b>1</b>
<b>Unit 2</b>	<b>Electricity.....</b>	<b>12</b>
<b>Unit 3</b>	<b>Changes Around Us .....</b>	<b>36</b>
<b>Unit 4</b>	<b>Cell Biology .....</b>	<b>57</b>
<b>Unit 5</b>	<b>Basis of Classification .....</b>	<b>70</b>
<b>Unit 6</b>	<b>Digital Painting .....</b>	<b>87</b>



E - book



Assessment



DIGI links



Let's use the QR code in the text books!

- Download DIKSHA app from the Google Play Store.
- Tap the QR code icon to scan QR codes in the textbook.
- Point the device and focus on the QR code.
- On successful scan, content linked to the QR code gets listed.
- Note: For ICT corner, Digi Links QR codes use any other QR scanner.



# Unit 1

## Heat and Temperature



### Learning Objectives

- ❖ To understand the working principle of thermometer
- ❖ To measure temperature using thermometer
- ❖ To know about Thermometric Liquids
- ❖ To differentiate between Clinical and Laboratory Thermometer
- ❖ To know the various units of temperature
- ❖ To convert a temperature from a thermometer scale to others.



## Introduction

You shiver when it is cold outside and sweat when it is hot outside, but how can you measure those weather temperatures? Temperature is involved in many aspects of our daily lives, including our own bodies and health; the weather; and how hot the stove must be in order to cook food.



**The measurement of warmness or coldness of a substance is known as its temperature.**

It is a measure of the average kinetic energy of the particles in an object. Temperature is related to how fast the atoms within a substance are moving.

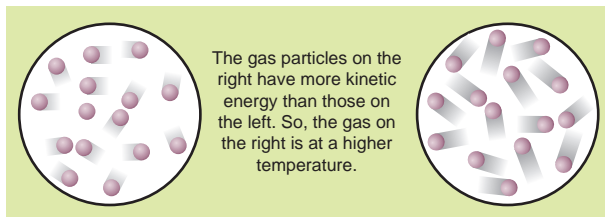

## 1.2 Temperature Units:

There are three units which are used to measure the temperature: Degree Celsius, Fahrenheit and Kelvin.

**Degree Celsius:** Celsius is written as  $^{\circ}\text{C}$  and read as degree. For example  $20^{\circ}\text{C}$ ; it is read as twenty degree Celsius. Celsius is called as Centigrade as well.

**Fahrenheit:** Fahrenheit is written as  $^{\circ}\text{F}$  for example  $25^{\circ}\text{F}$ ; it is read as twenty five degree Fahrenheit.

**Kelvin:** Kelvin is written as K. For example 100K; it is read as hundred Kelvin.

❖ The SI unit of temperature is kelvin (K).

## 1.3 Measuring Temperature

The temperature of the object is well approximated with the kinetic energy of the substances. The high temperature means that the molecules within the object are moving at a faster rate.



But the question arises, how to measure it? Molecules in any substance are very small to analyze and calculate its movement (Kinetic energy) in order to measure its temperature. You must use an indirect method to measure the kinetic energy of the molecules of a substance.

We studied that solids expands when heat is supplied to it. Like solid substances, liquids are also affected by heat. To know this let us do the activity 1.

**In a thermometer, when liquid gets heat, it expands and when it is cooled down, it contracts. It is used to measure temperature.**

Like solid and liquid objects, the effect of heat is also observed on gaseous objects.

## 1.4 Thermometer:

**Thermometer is the most common instrument to measure temperature.**

There are various kinds of thermometers. Some of them are like glass tubes which look thin and are filled with some kind of liquid.

**Why Mercury or Alcohol is used in Thermometer?**

Mostly Alcohol and Mercury are used in thermometers as they remain in liquid form even with a change of temperature in them. A small change in the temperature causes change in volume of a liquid. We measure this temperature by measuring expansion of a liquid in thermometer.

## ACTIVITY 1

### What is required?

A small glass bottle, a rubber cork, an empty refill, water, colour, a candle, a fork, a paper.

### What to do?

- Take a small glass bottle. Fill it with coloured water.
- Make hole at the centre of the rubber cork.
- Pass empty refill from the hole of the rubber cork.
- Make the bottle air tight and observe the water raised in the refill.
- Make a scale on paper, place it behind the refill and note down the position of the surface of water.
- Hold bottle with fork and supply heat to it with candle. Then observe.

### What is the change in the surface of water?

- 
- Stop the supply of heat. When water is cooled, observe the surface of water in the refill, **what change takes place? Why?**
- 

**When, a liquid is heated, it expands and when it is cooled down, it contracts.**



### Properties of Mercury:-

- Its expansion is uniform. (For equal amounts of heat it expands by equal lengths.)
- It is opaque and shining.
- It does not stick to the sides of the glass tube.
- It is a good conductor of heat.
- It has a high boiling point ( $357^{\circ}\text{C}$ ) and a low freezing point ( $-39^{\circ}\text{C}$ ). Hence a wide range of temperatures can be measured using a mercury thermometer

### Properties of Alcohol

- The freezing point of alcohol is less than  $-100^{\circ}\text{C}$ . So it can be used to measure very low temperatures.
- Its expansion per degree Celsius rise in temperature is very large.

- It can be coloured brightly and hence is easily visible.

### 1.4 Types of Thermometers

There are different types of thermometers for measuring the temperatures of different things like air, our bodies, food and many other things. Among these, the commonly used thermometers are clinical thermometers and laboratory thermometers.



#### 1.4.1 Clinical Thermometer

These thermometers are used to measure the temperature of a human body, at home, clinics and hospitals. All clinical thermometers have a kink that prevents the mercury from



## ACTIVITY 2

### What is required?

A big bottle, a balloon, threads, candle, water, fork

### What to do?

- Take one big bottle, and fill some water in it.
- Attach one balloon on the mouth of bottle and fix it with thread.
- Hold bottle with a fork. Heat the bottle with a candle and take observation.
- What change occurs in the state of balloon after heating the bottle?  
-----
- What change occurs in the state of balloon after heating the bottle?  
-----

### Why?

Now, let the bottle get cooled down.

### What change occurs in the state of balloon after bottle gets cool down?

### Why?

**When gases substance gets heat, it expands; when it cools it contracts.**

Why does a tyre get burst in summer? -----

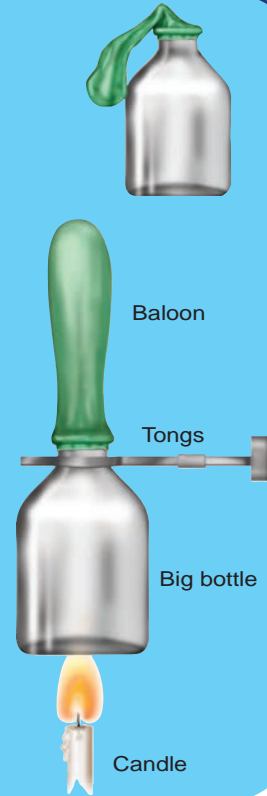

flowing back into the bulb when the thermometer is taken out of the patient's mouth, so that the temperature can be noted conveniently. There are temperature scales on either side of the mercury thread, one in Celsius scale and the other in Fahrenheit scale. Since the Fahrenheit scale is more sensitive than the Celsius scale, body temperature is measured in F only. A clinical thermometer indicates temperatures from a minimum of 35°C or 94°F to a maximum of 42°C or 108°F.



### Precautions to be Followed While Using a Clinical Thermometer

- The thermometer should be washed before and after use, preferably with an antiseptic solution.
- Jerk the thermometer a few times to bring the level of the mercury down.

- Before use, the mercury level should be below 35°C or 94°F.
- Do not hold the thermometer by its bulb.
- Keep the mercury level along your line of sight and then take the reading.
- Handle the thermometer with care. If it hits against some hard object, it may break.
- Do not place the thermometer in a hot flame or in the hot sun.

### 1.4.2 Laboratory Thermometers

Laboratory thermometers are used to measure the temperature in school and other laboratories for scientific research. They are also used in the industry as they can measure temperatures higher than what clinical thermometers can record. The stem and the bulb of a lab thermometer are longer when compared to that of a clinical thermometer and

there is no kink in the lab thermometer. A laboratory thermometer has only the Celsius scale ranging from  $-10^{\circ}\text{C}$  to  $110^{\circ}\text{C}$ .

### Precautions to be Followed While Using a Laboratory Thermometer

- Do not tilt the thermometer while measuring the temperature. Place it upright.
- Note the reading only when the bulb has been surrounded by the substance from all sides.



### ACTIVITY 3

#### Measure your body temperature

Wash the thermometer preferably with an antiseptic solution. Hold it firmly by the end and give it a few jerks. These jerks will bring the level of Mercury down. Ensure that it falls below  $35^{\circ}\text{C}$  ( $95^{\circ}\text{F}$ ). Now place the thermometer under your tongue or arm pit.

After one minute, take the thermometer out and note the reading. It tells you your body temperature. **What did you record as your body temperature?**\_\_\_\_\_

**DO YOU KNOW?**

In humans, the average internal temperature is  $37^{\circ}\text{C}$  ( $98.6^{\circ}\text{F}$ ), though it varies among individuals.

However, no person always has exactly the same temperature at every moment of the day. Temperatures cycle regularly up and down through the day according to activities and external factors.

### ACTIVITY 4

#### Use of Laboratory thermometer

- Take some water in a beaker.
- Take a laboratory thermometer and immerse its bulb end in water; holding it vertically. Ensure to dip whole portion of bulb end. The bulb end should not touch the bottom or side of the beaker.
- Observe the movement of rise of mercury. When it becomes stable, take the reading of the thermometer.
- Repeat this with hot water and take the reading.

### Difference between clinical and laboratory thermometer

Clinical Thermometer	Laboratory Thermometer
Clinical thermometer is scaled from $35^{\circ}\text{C}$ to $42^{\circ}\text{C}$ or from $94^{\circ}\text{F}$ to $108^{\circ}\text{F}$ .	Laboratory thermometer is generally scaled from $-10^{\circ}\text{C}$ to $110^{\circ}\text{C}$ .
Mercury level does not fall on its own, as there is a kink near the bulb to prevent the fall of mercury level.	Mercury level falls on its own as no kink is present.
Temperature can be read after removing the thermometer from armpit or mouth.	Temperature is read while keeping the thermometer in the source of temperature, e.g. a liquid or any other thing.
To lower the mercury level jerks are given.	No need to give jerk to lower the mercury level.
It is used for taking the body temperature.	It is used to take temperature in laboratory.

### 1.4.3 Digital Thermometer

Here is a lot of concern over the use of mercury in thermometers. Mercury is a toxic substance and



is very difficult to dispose of if a thermometer breaks. These days, digital thermometers are available which do not use mercury. Instead, it has a sensor which can measure the heat coming out from the body directly and from that can measure the temperature of the body.

Digital thermometers are mainly used to take the body temperature.



any object other than human body. Also we are advised to avoid keeping it in the sun or near a flame. Why?

A Clinical thermometer has small temperature range. The glass will crack/ burst due to excessive pressure created by expansion of mercury.



#### Maximum \_ minimum thermometer

The maximum and minimum temperatures of the previous day reported in weather reports are measured by a thermometer called the maximum - minimum thermometer.

### ACTIVITY 5

#### Use of Digital thermometer

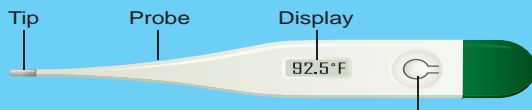

1. Wash the tip with warm (not hot), soapy water.
2. Press the "ON" button.
3. Insert the tip of the thermometer into the mouth, bottom, or under the armpit.
4. Hold the thermometer in place until it beeps (about 30 seconds).
5. Read the display.
6. Turn off the thermometer, rinse under water, and put it away in a safe place.

### Caution

Alex wanted to measure the temperature of hot milk using a clinical thermometer. His teacher stopped him from doing so.

We are advised not to use a clinical thermometer for measuring the temperature of

### 1.5 Scales of thermometers

#### Celsius scale

Celsius is the common unit of measuring temperature, termed after Swedish astronomer, **Anders Celsius** in 1742, before that it was known as Centigrade as thermometers using this scale are calibrated from (Freezing point of water)  $0^{\circ}\text{C}$  to  $100^{\circ}\text{C}$  (boiling point of water). In Greek, 'Centium' means 100 and 'Gradus' means steps, both words make it **centigrade** and later **Celsius**.

#### Fahrenheit Scale

Fahrenheit is a Common unit to measure human body temperature. It is termed after the name of a German Physicist **Daniel Gabriel Fahrenheit**. Freezing point of water is taken as  $32^{\circ}\text{F}$  and boiling point  $212^{\circ}\text{F}$ . Thermometers with Fahrenheit scale are calibrated from  $32^{\circ}\text{F}$  to  $212^{\circ}\text{F}$ .

#### Kelvin scale

Kelvin scale is termed after **Lord Kelvin**. It is the SI unit of measuring temperature and written as K also known as absolute scale as it starts from absolute zero temperature.



Temperature in Celsius scale can be easily converted to Fahrenheit and Kelvin scale as discussed ahead

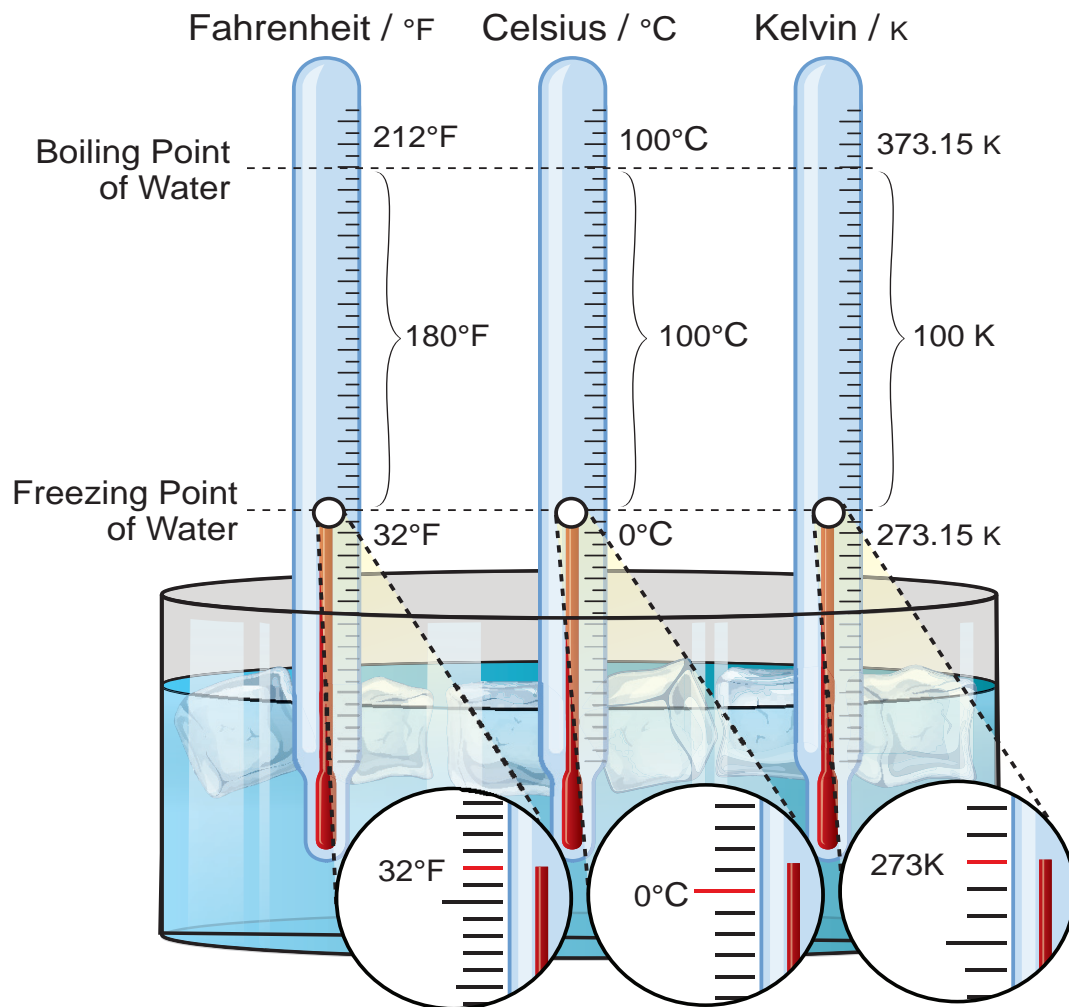

Relation between Fahrenheit scale and Celsius scales is as under.

$$\frac{(F-32)}{9} = \frac{C}{5}, \quad K = 273.15 + C$$

The equivalence between principal temperature scales are given in Table for some temperatures.

Temperature	Celsius scale (°C)	Fahrenheit scale (°F)	Kelvin scale (K)
Boiling point of water	100	212	373.15
Freezing point of water	0	32	273.15
Mean temperature of human body	37	98.6	310.15
Room temperature (Average)	72	23	296.15

# HEAT AND TEMPERATURE

## KEY CONTRIBUTORS

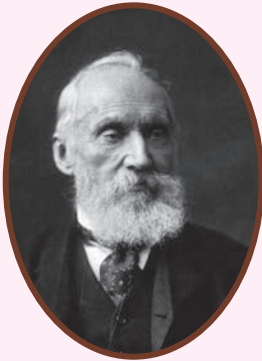

Lord Kelvin



Anders Celsius

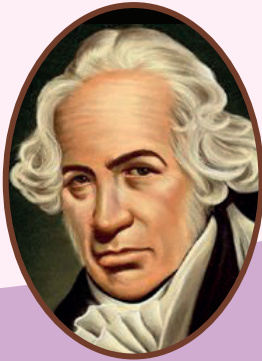

Gabriel Fahrenheit



Rankine

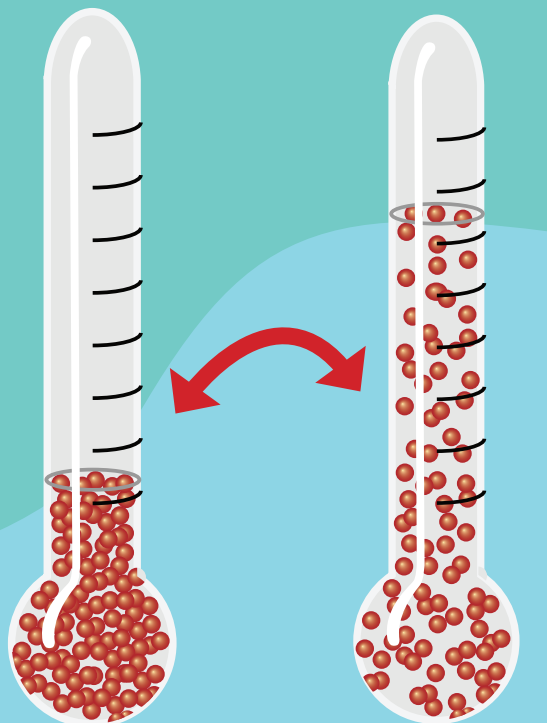

Low Temperature

High Temperature

**Thermometer Liquid Expands when Heated**

**10<sup>32</sup> KELVIN**

Temperature of the Universe in the earliest moments after the Big Bang



**373.15 KELVIN**

Boiling point of water

100 °C, 212 °F

**329.85 KELVIN**

Hottest natural temperature ever recorded on Earth.

56.7 °C, 134.06 °F

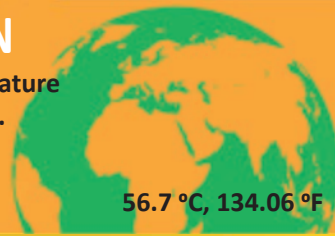

**310.15 KELVIN**

Average human body temperature

37 °C, 98.6 °F



**273.15 KELVIN**

Freezing point of water

0 °C, 32 °F



**178.45 KELVIN**

Coldest natural temperature ever recorded on Earth

-94.7 °C, -138.46 °F



**1 KELVIN**

The Boomerang Nebula maintains the coldest known natural temperature in the universe

-272.15 °C, -457.87 °F

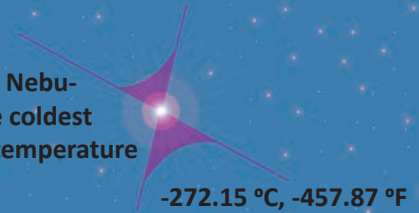

**0 KELVIN**

Absolute zero Temperature

-273.15 °C, -459.67 °F





Most of the people in the world use the Celsius scale to measure temperature for day to day purpose. The Kelvin scale has been designed in such a way, it is not only an absolute temperature scale, but also  $1^{\circ}\text{C}$  change is equal to a  $1\text{K}$  change. This makes the conversion from Celsius to absolute temperature scale (Kelvin scale) easy, just the addition or subtraction of a constant 273.15

But in United States they prefer to use the Fahrenheit scale. The problem is, converting Fahrenheit to absolute scale (Kelvin) is not easy.

To sort out this problem they use The Rankine scale. It named after the Glasgow University engineer and physicist **Rankine**, who proposed it in 1859. It is an absolute temperature scale, and has the property of having a  $1^{\circ}\text{R}$  change is equal to a  $1^{\circ}\text{F}$  change. Fahrenheit users who need to work with absolute temperature can be converted to Rankine by

$$R = F + 459.67$$

## 1.6 Numerical Problems

### Solved examples

1. How much will the temperature of  $68^{\circ}\text{F}$  be in Celsius and Kelvin?

**Given :**

$$\text{Temperature in Fahrenheit} = F = 68^{\circ}\text{F}$$

$$\text{Temperature in Celsius} = C = ?$$

$$\text{Temperature in Kelvin} = K = ?$$

$$\frac{(F-32)}{9} = \frac{C}{5}$$

$$\frac{(68-32)}{9} = \frac{C}{5}$$

$$C = 5 \times \frac{36}{9} = 20^{\circ}\text{C}$$

$$K = C + 273.15 = 20 + 273.15 = 293.15$$

Thus, the temperature in Celsius =  $20^{\circ}\text{C}$  and in Kelvin =  $293.15\text{K}$

2. At what temperature will its value be same in Celsius and in Fahrenheit?

**Given :** If the temperature in Celsius is  $C$ , then the temperature in Fahrenheit ( $F$ ) will be same,

$$\text{i.e. } F = C. \quad \frac{(F-32)}{9} = \frac{C}{5}$$

(or)

$$\frac{(C-32)}{9} = \frac{C}{5}$$

$$(C-32) \times 5 = C \times 9$$

$$5C - 160 = 9C$$

$$4C = -160$$

$$C = F = -40$$

The temperatures in Celsius and in Fahrenheit will be same at  $-40$

3. Convert the given temperature :

$$1) 45^{\circ}\text{C} = \dots\dots^{\circ}\text{F} \quad 2) 20^{\circ}\text{C} = \dots\dots^{\circ}\text{F}$$

$$3) 68^{\circ}\text{F} = \dots\dots^{\circ}\text{C} \quad 4) 185^{\circ}\text{F} = \dots\dots^{\circ}\text{C}$$

$$5) 0^{\circ}\text{C} = \dots\dots\text{K} \quad 6) -20^{\circ}\text{C} = \dots\dots\text{K}$$

$$7) 100\text{K} = \dots\dots^{\circ}\text{C} \quad 8) 272.15\text{K} = \dots\dots^{\circ}\text{C}$$

## POINTS TO REMEMBER

- The measurement of warmness or coldness of a substance is known as its temperature.
- There are three units which are used to measure the temperature: Degree Celsius, Fahrenheit and Kelvin.
- The SI unit of temperature is Kelvin (K).
- In a thermometer, when liquid gets heat, it expands and when it is cooled down, it contracts. It is used to measure temperature.

5. Relation between Fahrenheit scale and Celsius scales is

$$\frac{(F-32)}{9} = \frac{C}{5}$$

$$K = 273.15 + C$$



## EVALUATION



### I. Choose the correct answer

- International unit of measuring temperature is .....
  - Kelvin
  - Fahrenheit
  - Celsius
  - Joule
- In thermometer when bulb comes in contact with hot object, liquid inside it
  - expands
  - contracts
  - remains same
  - none of above
- The body temperature of a healthy man is;
  - 0°C
  - 37°C
  - 98°C
  - 100°C
- Mercury is often used in laboratory thermometers because it \_\_\_\_\_
  - is a harmless liquid
  - is silvery in colour and is attractive in appearance
  - Expands uniformly
  - is a low cost liquid
- Which of the following temperature conversions is incorrect

$$K \text{ (Kelvin)} = {}^{\circ}\text{C} \text{ (Celsius)} + 273.15$$

- |    |                      |         |
|----|----------------------|---------|
|    | ${}^{\circ}\text{C}$ | K       |
| a. | -273.15              | 0       |
| b. | -123.                | +150.15 |

- |    |        |          |
|----|--------|----------|
| c. | + 127. | + 400.15 |
| d. | + 450  | + 733.15 |

### II. Fill in the blanks

- Doctor uses \_\_\_\_\_ thermometer to measure the human body temperature.
- At room temperature Mercury is in \_\_\_\_\_ state.
- Heat energy transfer from \_\_\_\_\_ to \_\_\_\_\_
- 7°C temperature is \_\_\_\_\_ than 0°C temperature.
- The common laboratory thermometer is a \_\_\_\_\_ thermometer

### III. Match the following

i) Clinical thermometer	A form of energy
ii) Normal temperature of human body	100°C
iii) Heat	37°C
iv) Boiling point of water	0°C
v) Melting point of water	Kink

### IV. Give very short answer

- Temperature of Srinagar (J&K) is - 4°C and in Kodaikanal is 3°C which of them has greater temperature? What is the difference between the temperatures of these two places?
- Jyothi was prepared to measure the temperature of hot water with a clinical thermometer. Is it right or wrong? Why?
- A clinical thermometer is not used to measure the temperature of air, why?
- What is the use of kink in clinical thermometer?
- Why do we jerk a clinical thermometer before we measure the body temperature?



### V. Give short Answer

1. Why do we use Mercury in thermometers?  
Can water be used instead of mercury?  
What are the problems in using it?
2. Swathi kept a laboratory thermometer in hot water for some time and took it out to read the temperature. Ramani said it was a wrong way of measuring temperature. Do you agree with Ramani? Explain your answer.
3. The body temperature of Srinath is  $99^{\circ}\text{F}$ . Is he suffering from fever? If so, why?

### VI. Give long answer

1. Draw the diagram of a clinical thermometer and label its parts.
2. State the similarities and differences between the laboratory thermometer and the clinical thermometer.

### VII. Higher Order Thinking questions

1. What must be the temperature in Fahrenheit, so that it will be twice its value in Celsius?
2. Go to a veterinary doctor (a doctor who treats animals). Discuss and find out the normal temperature of domestic animals and birds.

# Unit 2

## ELECTRICITY

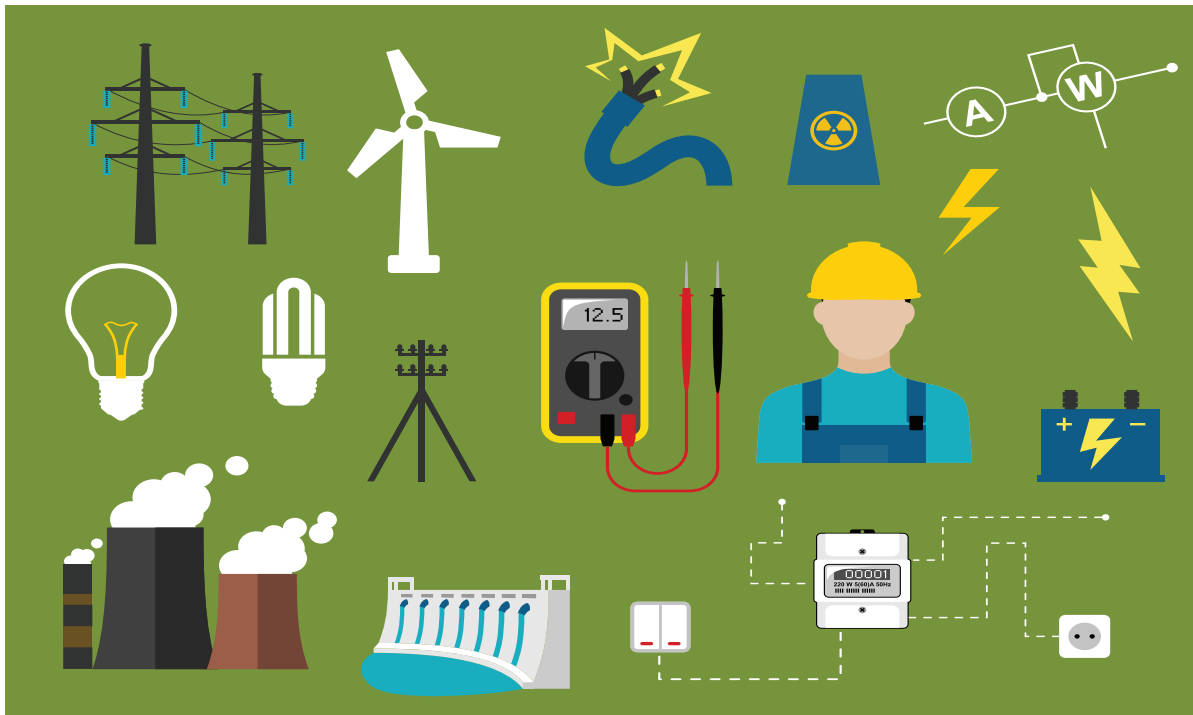

### Learning Objectives

- ❖ Understanding the flow of electric current and learning to draw the circuit diagram
- ❖ Understanding the difference between conventional current and electron flow.
- ❖ Understanding the different types of circuit based on flow of electricity and the connection of bulbs in a circuit
- ❖ Distinguishing a cell and a battery
- ❖ Understanding the effects of electric current and factors affecting the effect of electric current
- ❖ Applying their knowledge in identifying the components of electrical circuits.
- ❖ Understanding the discrimination between different type of circuits.
- ❖ Doing numerical problems and drawing the circuit diagram of their own.





## Introduction

In 1882, when it was sun set in the west that miracle happened in New York city. When Thomas Alva Edison gently pushed the switch on 14,000 bulbs in 9,000 houses suddenly got lighted up. It was the greatest invention to mankind. From then the world was under the light even in the night.

Many countries began using electricity for domestic purposes. Seventeen years after the New York, in 1899 electricity first came to India. The Calcutta Electric Supply Corporation Limited commissioned the first thermal power plant in India on 17 April 1899

Around 1900s, a thermal power station was set up at Basin Bridge in Madras city and power was distributed to the government press, general hospital, electric tramways and certain residential areas in Madras. Today electricity is a common household commodity.



In your class 6, we learned about electricity and their sources. From operating factories, running medical equipments like ventilator, communications like mobile, radio and TV, drawing water to the agricultural field and light up homes electricity is important. What is electricity? We can see that. it is a form of energy, like heat and magnetism.

We have learnt that all materials are made up of small particles called atoms. The centre

of the atom is called the nucleus. The nucleus consists of protons and neutrons. Protons are positively charged. Neutrons have no charge. Negatively charged electrons revolve around the nucleus in circular orbits. Electricity is a form of energy that is associated with electric charges that exists inside the atom

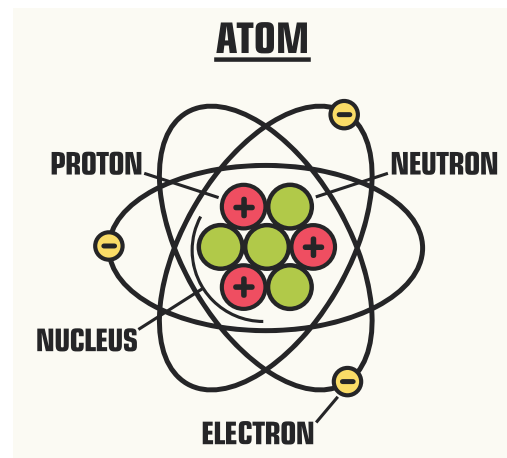

## ACTIVITY 1

Comb your dry hair. Immediately after combing the dry hair, bring the comb closer to the bits of paper. What will you observe?

When you are getting up from the plastic chair, the nylon shirt seems to be stuck to



the chair and make crackling sound. What is the reason for the creation of the sound? A balloon sticks to wall without any adhesive after rubbing on your hand.

Do you know the reason for all?

In all the above activities, when a body is rubbed against some other body become charged.

Electric charge is measured in a unit called coulomb. One unit of coulomb is charge of approximately  $6.242 \times 10^{18}$  protons or electrons.

Electrical charges are generally denoted by the letter 'q'

## 2.1. Electric Current

The flow of electric charges constitute an electric current. For an electrical appliance to work, electric current must flow through it. An electric current is measured by the amount of electric charge moving per unit time at any point in the circuit. The conventional symbol for current is 'I'.

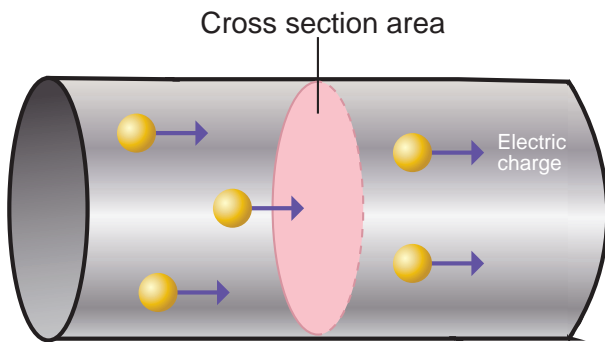

### Unit of Electric Current

The SI unit for measuring an electric current is the ampere, which is the flow of electric charge across a surface at the rate of one coulomb per second.

$$I = q / t$$

Where I ⇒ current (in Ampere - A)

q ⇒ charge (in coulomb - c)

t ⇒ time taken (in seconds - s)

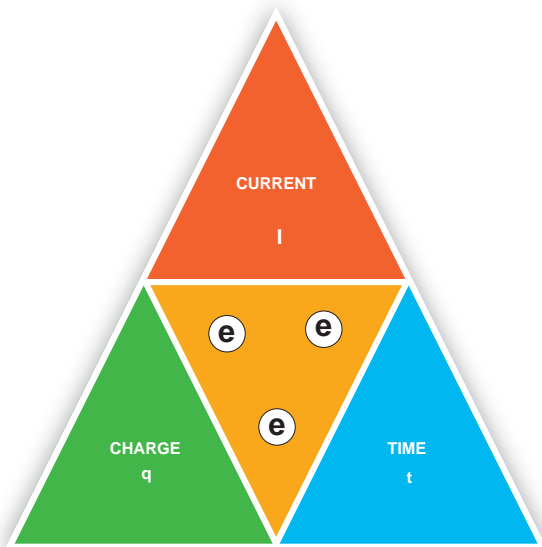

### Worked example 2.1

If 30 coulomb of electric charge flows through a wire in two minutes, calculate the current in the wire?

#### Solution

Given :

Charge (q) = 30 coulomb

Time (t) = 2 min x 60s  
= 120 s

Current I = q/t = 30C/120s = 0.25 A

### 2.1.1. Conventional Current and Electron Flow

#### Conventional Current

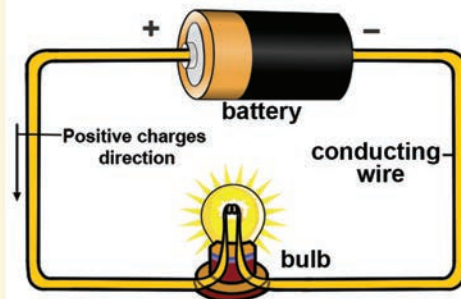

Conventional current flow from the positive to the negative end

#### Electron Flow

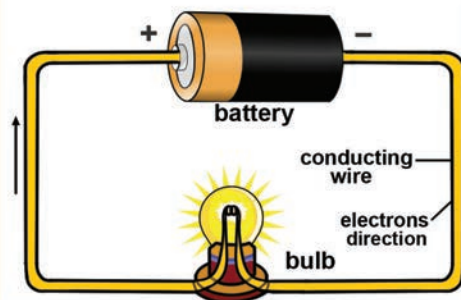

Electric charges flow from the negative to the positive end

Before the discovery of electrons, scientists believed that an electric current consisted of moving positive charges.



This movement of positive charges is called conventional current.

After the electrons were discovered, it was known that electron flow actually takes place from the negative terminal to the positive terminal of the battery. This movement is known as electron flow.

Conventional current is in the direction opposite to electron flow.

### 2.1.2. Measurement of electric current

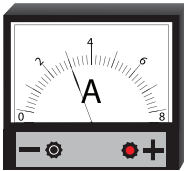

Electric current is measured using a device called ammeter. The terminals of an ammeter are marked with + and - sign. An ammeter must be connected in series in a circuit.

Instruments used to measure smaller currents, in the milli ampere or micro ampere range, are designated as milli ammeters or micro ammeters.

1 milliampere (mA) =  $10^{-3}$  ampere.  
= 1/1000 ampere  
1 microampere ( $\mu\text{A}$ ) =  $10^{-6}$  ampere  
= 1/1000000 ampere

### Worked Examples 2.2

If 0.002A current flows through a circuit, then convert the current in terms of micro ampere?

#### Solution:

Given that the current flows through the circuit is 0.002A

We know that

$$1 \text{ A} = 10^6 \mu\text{A}$$

$$0.002\text{A} = 0.002 \times 10^6 \mu\text{A}$$

$$= 2 \times 10^{-3} \times 10^6 \mu\text{A}$$

$$= 2 \times 10^3 \mu\text{A}$$

$$0.002\text{A} = 2000 \mu\text{A}$$

### 2.2. Potential difference (v)

Electrical charges need energy to push them along a circuit.

Water always flows from higher to lower ground. Similarly an electric charge always flows from a point at higher potential to a point at lower potential.



An electric current can flow only when there is a potential difference (V) or P.D.

The potential difference between any two points in the circuit is the amount of energy needed to move one unit of electric charge from one point to the other.

#### 2.2.1. Unit of potential difference

Did you ever notice the precautionary  board while crossing the railway track and the electrical transformer? What does the word high voltage denotes?



The term mentioned in the board volt is the measurement for the electric potential difference.

The SI unit of potential difference is volt (V). potential difference between two points is measured by using a device called voltmeter.

Water at the top of the waterfall has more potential energy



Water near the base of the waterfall has less potential energy

The electric current flow from the higher potential level to the lower potential level is just like the water flow.

### 2.2.2. Electrical conductivity and Resistivity

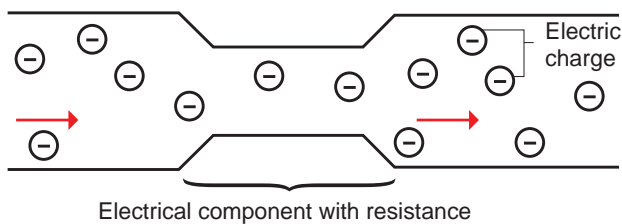

#### Resistance (R)

An electrical component resists or hinders the flow of electric charges, when it is connected in a circuit. In a circuit component, the resistance to the flow of charge is similar to how a narrow channel resists the flow of water.

The higher the resistance in a component, the higher the potential difference needed to move electric charge through the component. We can express resistance as a ratio.

Resistance of a component is the ratio of the potential difference across it to the current flowing through it.  $R = \frac{V}{I}$

The S.I unit of resistance is ohm

Greater the ratio of V to I, the greater is the resistance

#### Electrical conductivity ( $\sigma$ )

Electrical conductivity or specific conductance is the measure of a material's ability to conduct an electric current. It is commonly represented by the Greek letter  $\sigma$  (sigma) The S.I Unit of electrical conductivity is Siemens/meter(S/m)

#### Electrical resistivity ( $\rho$ )

Electrical resistivity (also known as specific electrical resistance, or volume resistivity) is a fundamental property of a material that quantifies how strongly that material opposes the flow of electric current. The SI unit of electrical resistivity is the ohm-metre ( $\Omega \cdot m$ ).

Material	Resistivity ( $\rho$ ) ( $\Omega \cdot m$ ) at 20°C	Conductivity ( $\sigma$ ) (S/m) at 20°C
Silver	$1.59 \times 10^{-8}$	$6.30 \times 10^7$
Copper	$1.68 \times 10^{-8}$	$5.98 \times 10^7$
Annealed Copper	$1.72 \times 10^{-8}$	$5.80 \times 10^7$
Aluminum	$2.82 \times 10^{-8}$	$3.5 \times 10^7$

### 2.2.3. Analogy of Electric Current with Water Flow

An electric current is a flow of electrons through a conductor (like a copper wire). We can't see electrons, however, we can imagine the flow of electric current in a wire like the flow of water in a pipe.

Let us see the analogy of flow of electric current with the water flow.

Water flowing through pipes is pretty good mechanical system that is a lot like an electrical circuit. This mechanical system consists of a pump pushing water through a closed pipe. Imagine that the electrical current is similar to the water flowing through the pipe. The following parts of the two systems are related

- The pipe is like the wire in the electric circuit and the pump is like the battery.
- The pressure generated by the pump drives water through the pipe.
- The pressure is like the voltage generated by the battery which drives electrons through the electric circuit.
- Suppose, there are some dust and rust that plug up the pipe and slow the flow of water, creating a pressure difference from one end to the other end of the pipe. In similar way, the resistance in the electric circuit resists the flow of electrons and creates a voltage drop from one end to the other. Energy loss is shown in the form of heat across the resistor.

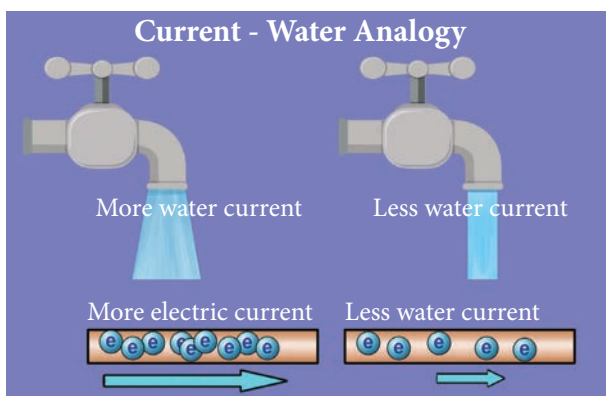

### 2.3. Sources of Electric current - Electro chemical cells or electric cells

An electric cell is something that provides electricity to different devices that are not fed directly or easily by the supply of electricity.

### ACTIVITY 2

Shall we produce electricity at our home?

#### Materials required:

Zinc and copper electrodes, a light bulb, connecting wires, and fruits such as lemons, orange, apples, grapes, and bananas.

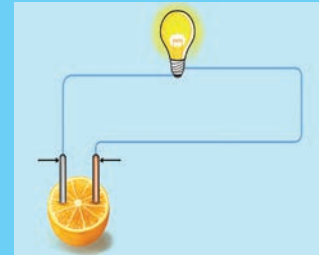

#### Procedure:

1. Set up a circuit as shown in figure
2. Note the brightness of the bulb when the circuit is connected to a lemon.
3. Repeat the experiment using the other fruits listed above. Do you notice the differences in the brightness of the bulb when it is connected to different fruits? Which fruit gives the greatest brightness? Why? (If you do not know please get the appropriate reason from your teacher)





#### Inference:

In the above activity what makes enabled the bulb to glow. Why there is a difference in the brightness of the bulb? The reason is that the fruits which you have connected to the bulb produces the electric energy at different levels

The sources which produce the small amount of electricity for shorter periods of time is called as electric cell or electro chemical cells. Electric cell converts chemical energy into electrical energy

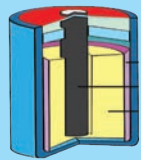
In addition to electro chemical, we use electro thermal source for generating electricity for large scale use.

It has two terminals. When electric cells are used, a chemical reaction takes place inside the cells which produces charge in the cell.

Primary Cell	Secondary Cell			
Dry cell	Lithium cylindrical cells	Button cells	Alkaline cells	Automobile battery
				

### 2.3.1. Types of cell – primary cell and secondary cell

In our daily life we are using cells and batteries for the functioning of a remote, toys cars, clock, cellphone etc. Event hough all the devices produces electrical energy, some of the cells are reusable and some of them are of single use. Do you know the reason why? Based on their type they are classified into two types namely – primary cell and secondary cell.

#### Primary cell

The dry cell commonly used in torches is an example of a primary cell. It cannot be recharged after use.

#### Secondary cells

Secondary cells are used in automobiles and generators. The chemical reaction in them can be reversed, hence they can be recharged. Lithium cylindrical cells, button cells and alkaline cells are the other types that are in use.

#### ACTIVITY 3

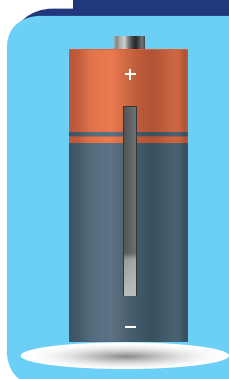

I am so exhausted. I am going to faint. What first aid will you give me to wake up?

### 2.3.2. Difference between primary cell and secondary cell

PRIMARY CELL	SECONDARY CELL
1. The chemical reaction inside the primary cell is irreversible	The chemical reaction inside the secondary cell is reversible
2. It cannot be recharged.	It can be recharged
3. Examples of secondary cells are lead accumulator, Edison accumulator and Nickel – Iron accumulator.	It is used to operate devices such as mobile phones, cameras, computers, and emergency lights.
4. Examples- simple voltaic cell, Daniel cell, and lechlanche cell and dry cell	Examples of secondary cells are lead accumulator, Edison accumulator and Nickel – Iron accumulator.

### 2.3.3. Primary cell – simply Dry cell

A dry cell is a type of chemical cell commonly used in the common form batteries for many electrical appliances. It is a convenient source of electricity available in portable and compact form. It was developed in 1887 by Yei Sakizo of Japan.



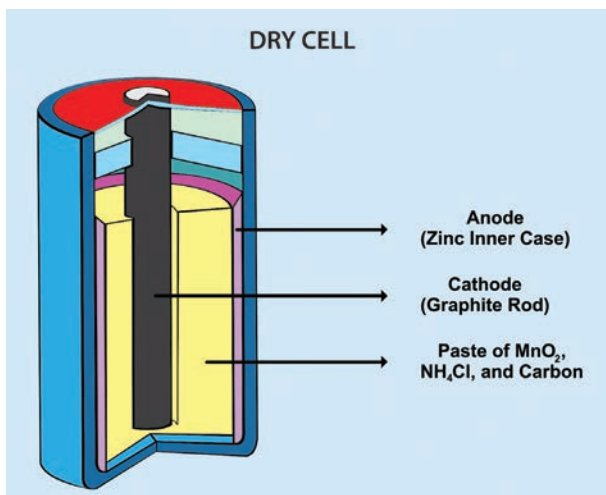

Dry cells are normally used in small devices such as remote control for T.V., torch, camera and toys.

A dry cell is a portable form of a leclanche cell. It consists of zinc vessel which acts as a negative electrode or anode. The vessel contains a moist paste of saw dust saturated with a solution of ammonium chloride and zinc chloride.

The ammonium chloride acts as an electrolyte.

Electrolytes are substances that become ions in solution and acquire the capacity to conduct electricity.

The purpose of zinc chloride is to maintain the moistness of the paste being highly hygroscopic. The carbon rod covered with a brass cap is placed in the middle of the vessel. It acts as positive electrode or cathode.

It is surrounded by a closely packed mixture of charcoal and manganese dioxide ( $\text{MnO}_2$ ) in a muslin bag. Here  $\text{MnO}_2$  acts as depolarizer. The zinc vessel is sealed at the top with pitch or shellac. A small hole is provided in it to allow the gases formed by the chemical action to escape. The chemical action inside the cell is the same as in leclanche cell.

The dry cell is not really dry in nature but the quantity of water in it is very small, as the electrolyte is in the form of a paste. In other cells, the electrolyte is usually a solution



### 2.3.4. Batteries

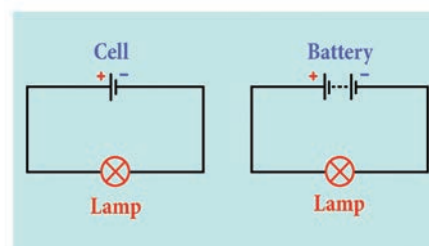

Batteries are a collection of one or more cells whose chemical reactions create a flow of electrons in a circuit. All batteries are made up of three basic components: an anode (the '+' side), a cathode (the '-' side), and some kind of electrolyte. Electrolyte is a substance that chemically reacts with the anode and cathode.

### 2.3.5. Invention of the Battery



One fateful day in 1780, Italian physicist, physician, biologist, and philosopher, Luigi Galvani, was dissecting a frog attached to a brass hook. As he touched the frog's leg with an iron scalpel, the leg twitched.

Galvani theorized that the energy came from the leg itself, but his fellow scientist, Alessandro Volta, believed otherwise.

Volta hypothesized that the frog's leg impulses were actually caused by different metals soaked in a liquid.



He repeated the experiment using cloth soaked

in brine instead of a frog corpse, which resulted in a similar voltage. Volta published his findings in 1791 and later created the first battery, the voltaic pile, in 1800.



The invention of the modern battery is often attributed to Alessandro Volta. It actually started with a surprising accident involving the dissection of a frog.

### 2.4. ELECTRIC SWITCH

Our country faces a shortage of electricity. So wastage of electricity means you are depriving someone else of electricity. Your electricity bill goes up. So, we must use electricity very carefully and only when it is needed. We must use the electricity as long as we need it in our house hold activities.

Can you remember what you did last year to turn the current on or off?



This time, we shall use a switch to turn the current on or off. You may have used different kinds of switches to turn your household electric appliances on or off. Switches help us to start or stop the appliances safely and easily.

### ACTIVITY 4

#### Make your own switch

Let us make a switch of our circuits. Take 10 cm – long iron strip. Bend it twice as shown in figure. Now drive a nail into the bend of the wooden

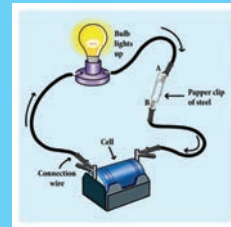

block. Nail one end of the strip to the other end of the wooden block so that its free end rests just above the first nail without touching it. Your switch is ready.

Would you like to test your switch? To do so, first set up the circuit as shown in the figure.

How would you use the switch to open or close the circuit.

If the bulb in your circuit glows when the metal strip of your switch is pressed on the nail and turns off when it is not, then your switch is working. The switch you made is a simple one. You may have seen many different types of switches on switchboards and appliances at your home and school. The switches are designed according to their usage, convenience and safety. But all of them work on the same principle. Switch is a mechanical component that consists of two or more terminals that are internally connected to a metal strip. Commonly used switches are listed below:

Tapping key		Toggle switch		Illuminated switch	
Plug key		Rocker switch		Slide switch	

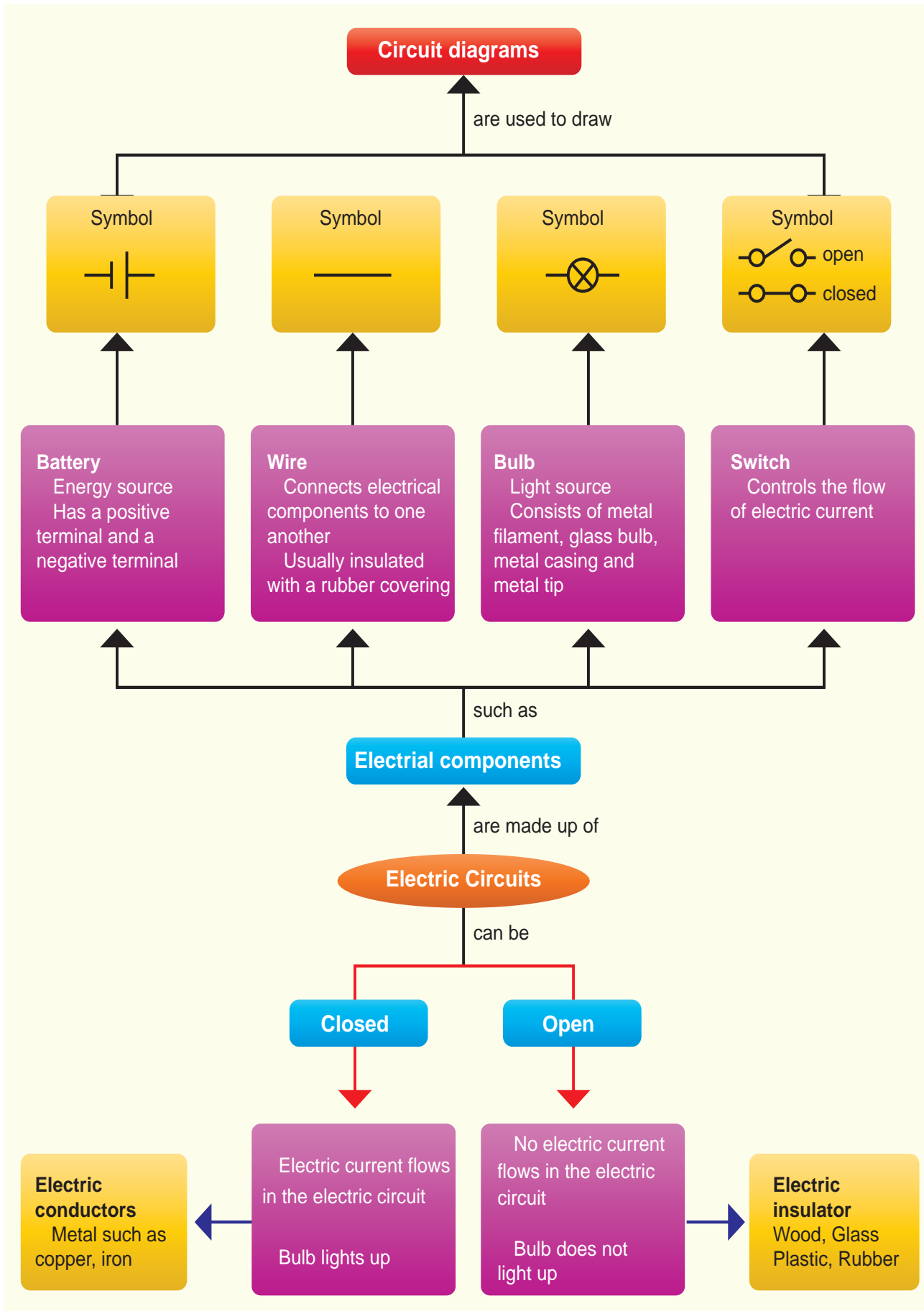

## 2.5. Electric circuit

It is difficult to draw a realistic diagram of this circuit. The electrical appliances you use at home have even more difficult circuits. Can you draw realistic diagrams of such circuits which contain many bulbs, cells, switches and other components? Do you think it is easy? It is not easy.

Scientists have tried to make the job easier. They have adopted simple symbols for different components in a circuit. We can draw circuit diagrams using these symbols.

Symbols for bulbs, cells and switches are shown in figure.

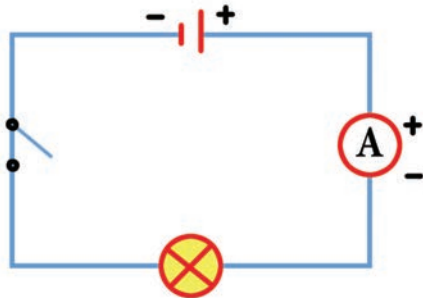

In a cell, the longer line denotes the positive (+) terminal and the short line denotes the negative (-) terminal. We shall use these symbols to show components in the circuits we draw. Such diagrams are called circuit diagrams.

**DO YOU KNOW?**

All muscles of our bodies move in response to electrical impulses generated naturally in our bodies

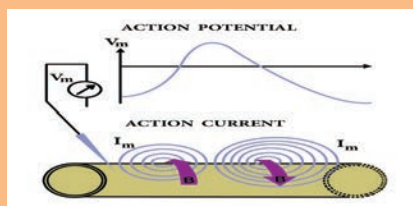
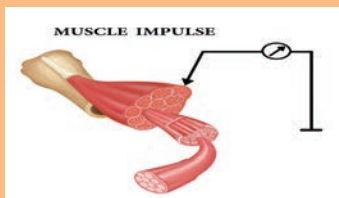

### 2.5.1. Types of electrical circuits

In the above experiment, we make a circuit with a bulb and a cell. We make only one kind of the circuit with a cell and a bulb. But we can make many types of circuits if we have more than one bulb or cells by connecting these components in different ways.

### 2.5.2. Series circuit

Two kinds of circuits can be made with two bulbs and a cell. In this experiment we shall make one of them and study it.

Look at the circuit with two bulbs, and a cell and a switch given here (Figure)

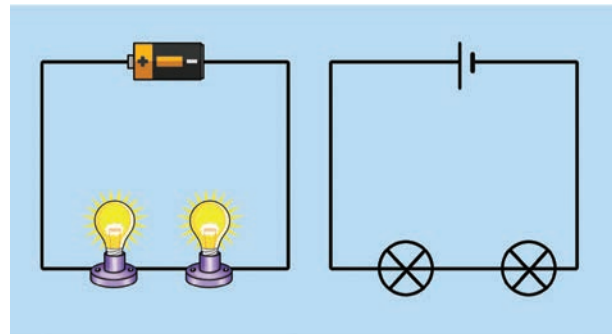

It is clear from the circuit diagram, that the two bulbs are connected one after the other. The circuit diagram shows the sequence of the bulbs and cell, not their real position. The way in which the bulbs have been connected in this circuit is called series connection.

Now make the circuit by joining the two bulbs and cell. Do both the bulbs light up? Do both glow equally bright? If one glows less bright, will it shine more brightly if we change its place in the sequence? Change the sequence of bulbs and notice.

Sometimes bulbs appear to be similar can differ from each other. So, similar looking bulb do not always glow equally bright when connected in series. The circuit can be broken at several places. For example, between the cell and the bulb, between the two bulbs etc.



### 2.5.3 Parallel Circuit

Figure - shows a circuit in which two bulbs are connected in different places. This is a second type of circuit. Two bulbs in this circuit are said to be connected in parallel and such circuits are called parallel circuits.

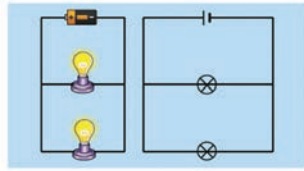

### 2.5.4. Similarity and Difference between Series and Parallel Circuit

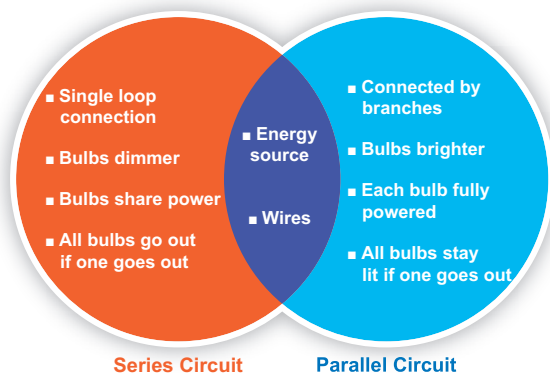

### Science to mind pricking

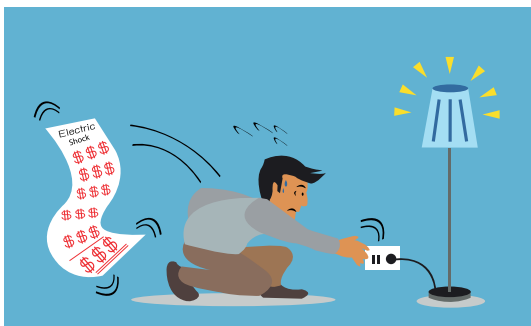

If an electrician attending an electrical fault at your home gets current shock, will you touch him in order to get rid off him from current risk? Will you use the wet stick to beat him to avoid further effects of electric shock?

Why do the electric line man are wear rubber gloves in their hands while doing electrical works on a electrical pole?

We know that all materials are made up of the basic building block, the 'atom'. An atom, in turn,

contains electrically charged particles. Many of these particles are fixed to the atoms but in conductors (such as all metals) there are lots of particles that are not held to any particular atom but are free to wander around randomly in the metal. These are called 'free charge'.



#### Short circuit

You might have observed the



spark in the electric pole located nearby your house. Do you know the cause of this electric spark? This is due to the short circuiting of electricity along its path. A short circuit is simply a low resistance connection between the two conductors supplying electrical power to any circuit. Arc welding is a common example of the practical application of the heating due to a short circuit.

### 2.6. Conductors And Insulators

Based on the property of conductance of electricity, substances are classified into two types, namely, Conductors and Insulators (or) bad conductors of electricity



The electrons of different types of atoms have different degrees of freedom to move around. With some types of materials, such as metals, the outermost electrons in the atoms are loosely bound and they chaotically move in the space between the atoms of that material. Because these virtually unbound electrons are free to leave their respective atoms and float around in the space between adjacent atoms, they are often called as free electrons.

# Electricity

Electric current is the flow of electric charges, typically through wires, conductors and electric devices

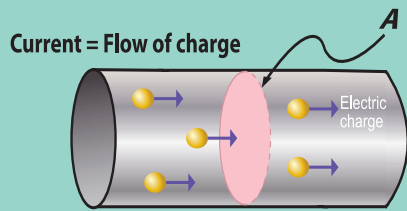

## Conventional current and Electric current

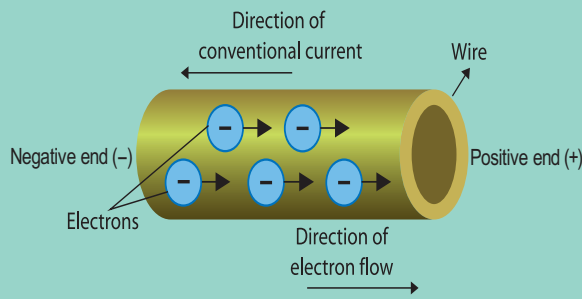

**Conventional current**

Conventional current flow is from positive (+) to negative (-)

**Electric current**

Electric current flow is from (-) negative to (+) positive

$$\text{Electric current } I = Q/t$$

## Water current vs electric current - Analogy

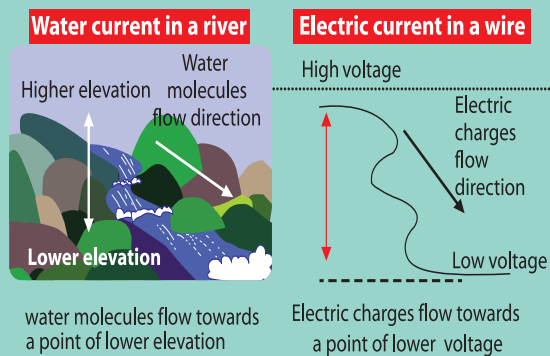

## Open circuit

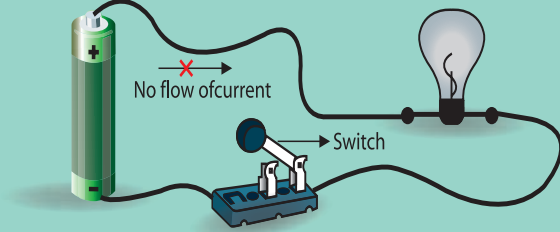

An incomplete electrical circuit in which no current flows

## Closed circuit

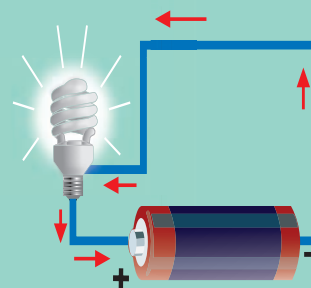

An electric circuit providing an uninterrupted endless path for the flow of current

## Series circuit

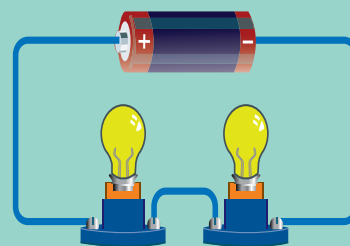

Circuit that has only one closed path through which the electric current flows

## Parallel circuit

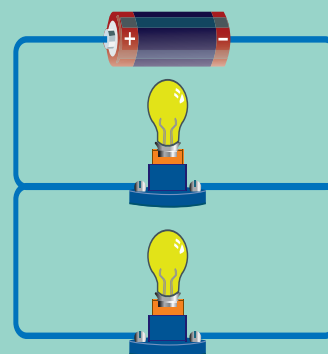

Circuit that Offers more than one path for the flow of electric current

Let's imagine that we have a metal in the form of a wire. When a voltage is connected across the ends of the metal wire, the free electrons drift in one direction.

So, a really good conductor is one that has lots of free charges while those who don't have enough 'free charges' would not be good at conducting electricity or we can say that they would be 'poor conductors' of electricity.

### 2.6.1. Conductors

Conductors are the materials whose atoms have electrons that are loosely bound and are free to move through the material. A material that is a good conductor gives very little resistance to the flow of charge (electron) on the application of external voltage. This flow of charge (electron) is what constitutes an electric current. A good conductor has high electrical conductivity in the above activity.

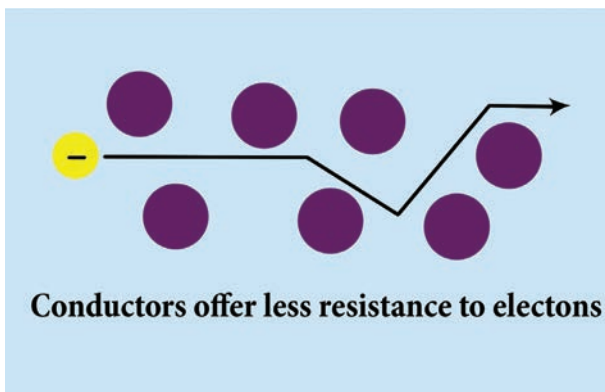

In general, more the free electrons, the better the material will conduct (for a certain applied voltage).

### 2.6.2. Insulators

Those materials which don't have enough 'free electrons' are not good at conducting electricity or we can say that they would be 'poor conductors' of electricity and they are called insulators.

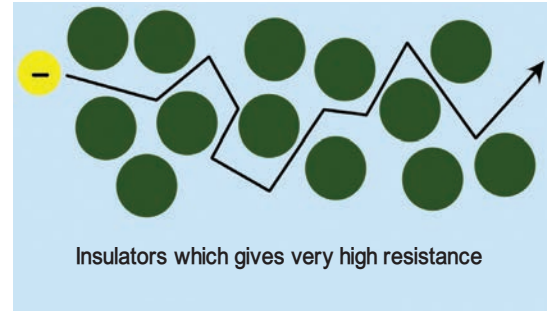

This is the material used in SIM Cards, Computers, and ATM cards. Do you know by which material I am made up off?

The chip which are used in SIM Cards, Computers, and ATM cards are made up of semiconductors namely, silicon and germanium because of their electrical conductivity lies between a conductor and an insulator.



An insulator gives a lot of resistance to the flow of charge (electron). During the drift of the electrons in an object when an external voltage is applied, collisions occur between the free electrons and the atoms of the material also affect the movement of charges. These collisions mean that they get scattered. It is a combination of the number of free electrons and how much they are scattered that affects how well the metal conducts electricity. The rubber eraser does not allow electric current to pass through it. So rubber is a non-conductor of electricity. Rubber is an insulator

Most of the metals are good conductors of electricity while most of the non-metals are poor conductors of electricity.



Wires made of copper, an electrical conductor, have very low resistance. Copper wires are used to carry current in households. These wires are in turn enclosed in electrical insulators, or materials of high electrical resistance. These materials are usually made of flexible plastic.



## 2.7. Effects of Electric Current



You performed many experiments with electricity in Class 6 and learned quite a few interesting facts. For example, you saw that a bulb can be made to light up by making electricity flow through it. The light of the bulb is thus one of the effects of electricity. There are several other important effects of electricity. We shall study some of these effects in this chapter. There are 3 main effects of electricity as,

- Heating effect
- Magnetic effect (Magnetism)
- Chemical effect

### 2.7.1. Heating effect

When an electric current passes through a wire, the electrical energy is converted to heat. In heating appliances, the heating element is made up of materials with high melting point. An

example of such a material is nichrome (an alloy of nickel, iron and chromium).

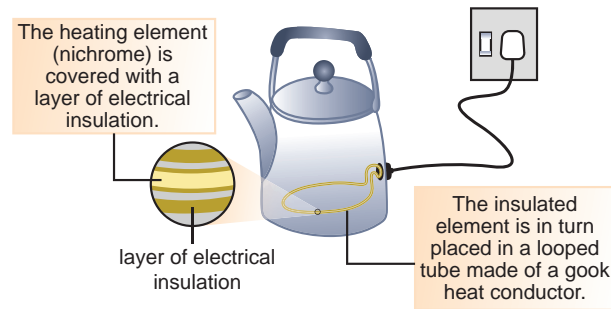

The heating effect of electric current has many practical applications. The electric bulb, geyser, iron box, immersible water heater are based on this effect. These appliances have heating coils of high resistance.

Generation of heat due to electric current is known as the heating effect of electricity.

## Factors affecting Heating Effect of current

1. Electric Current
2. Resistance
3. Time for which current flows

### Electric Fuse

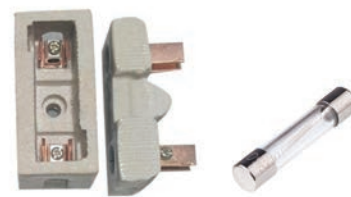

Electric fuse is a safety device which is used in household wiring and in many appliances. Electric fuse has a body made of ceramic and two points for connecting the fuse wire. The fuse wire melts whenever there is overload of the current in the wire. This breaks the circuit and helps in preventing damage to costly appliances and to the wiring. In electrical devices, a glass fuse is often used. This is a small glass tube, in which lies the fuse wire.

## Effects of Electric current

### Magnetic effect

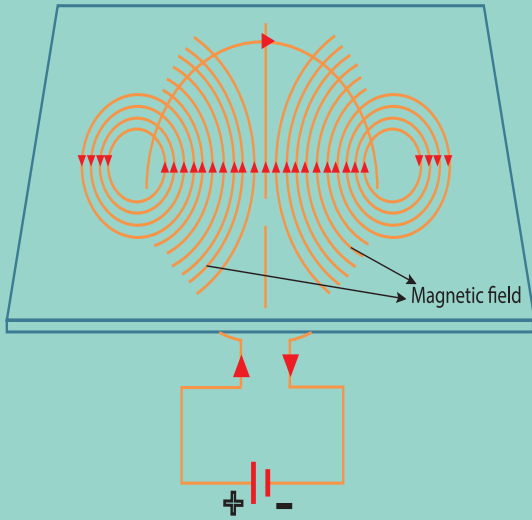

Production of magnetic field when the current flows through the coil of wire

### Cell

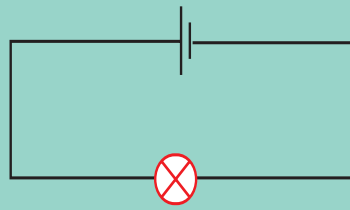

Cell is the basic electrochemical unit that converts chemical energy into electrical energy

### Battery

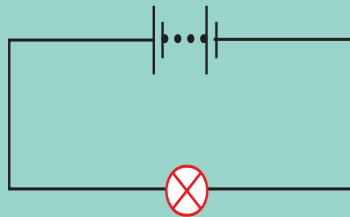

Battery is a group of cells

### Heating effect

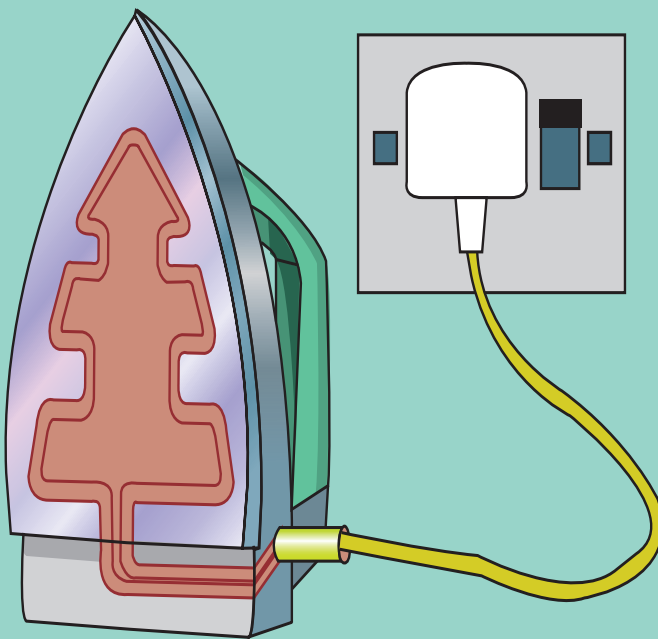

Production of heat by flow of electric current in a circuit

### Chemical effect

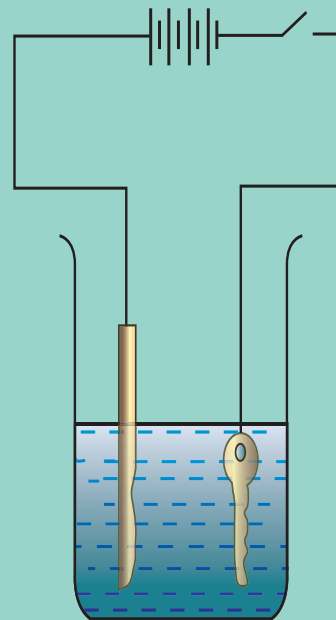

Chemical reaction happens when electricity passes through various conducting liquids



## MCBs (Miniature Circuit Breaker)



MCBs have been replacing electric fuse from wirings at most of the places. The electric fuse has a big practical problem. Whenever the wire fuses, one needs to replace the wire to resume electric supply. More often than not, this proves to be a cumbersome task. Miniature circuit breakers break the circuit automatically. One just needs to switch it on to resume the electric supply. Many models of MCBs have a built in mechanism by which the electric supply is automatically resumed.

### 2.8. Magnetic Effect of electricity

The next effect of electric current is Magnetism. In 1819, Hans Christian Oersted discovered the electricity that has a magnetic effect. The experiment in activity-5 will help you understand the magnetic effect of electric current.

#### 2.8.1. Application of magnetic effect of electric current - Electromagnet

Magnetic effect of electric current has been used in making powerful electromagnets. Electromagnets are also used to remove splinters of steel or iron in hospitals dealing with eye injuries.

Electro magnets are used in many appliances that we use in our day to day life, namely, electric bell, cranes and telephone. Let us know how the magnetic effect of electric current is applied in telephones.

### ACTIVITY 5

#### Materials required

- Iron nail
- Battery & Switch
- Wire

Take around 75 cm long piece of insulated flexible wire and an iron nail say about 8 - 10 cm long. Wind the wire tightly around the nail in the form of a coil. Connect the free ends of the wire to the terminals of a cell as shown. Place some pins on or near the end of the nail. Now switch on and switch off the current, What happens?

When the switch is kept in on position the pins starts to cling to the end of the nail.

When the electric current is switched off the coil generally loses its magnetism. Such coils are called as electromagnets.

The polarities of both ends of the coil changes according to the direction of electric current passes.

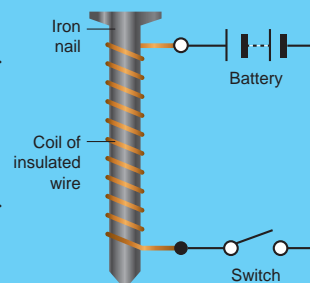

#### 2.8.2. Telephone

In telephones, a changing magnetic effect causes a thin sheet of metal (diaphragm) to vibrate. The diaphragm is made up a metal that can be attracted to magnets.

1. The diaphragm is attached to spring that is fixed to the earpiece.
2. When a current flows through the wires, the soft - iron bar becomes an electromagnet.

## The world comes to brightness

Thomas Alva Edison (1847-1931)

Thomas Alva Edison was affected by scarlet fever and hence he joined the school at Fort Huron in America only at the age of eight.

When he was a child his hearing capacity was reduced. One day his teacher scolded him vehemently, On that day, he dropped out of the school.



After leaving the school, his mother who was a teacher taught lessons at home for three years.

Since the age of seven, Edison was interested towards domestic electrical devices. At the age of 9, he read the book, "Natural and Experimental Philosophy" written by Richard Parker. At the age of 21, he read deeply Michal Faraday's "Experimental Researches in Electricity".



Edison worked as a telegraph operator in a railway station. He was the dynamic telegraph operator. His first invention was electrical telegraph and its related instruments.



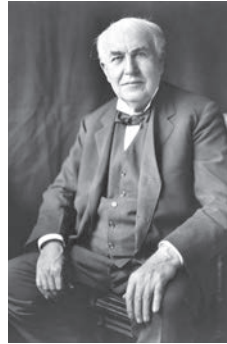

He invented an advanced instrument Gramophone in 1877.

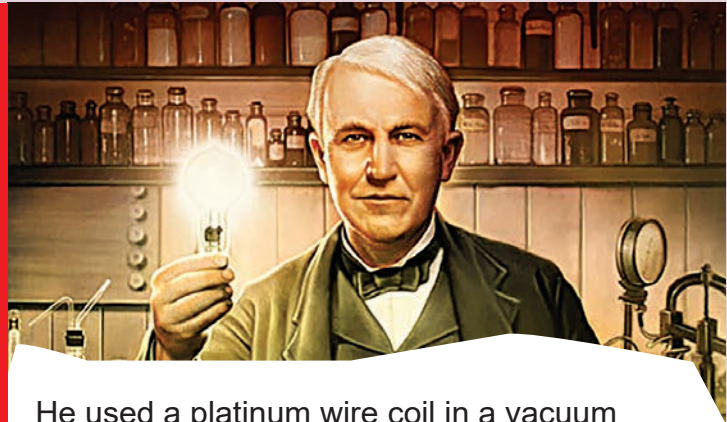

He used a platinum wire coil in a vacuum glass and discovered the first electric bulb in 1879.

Thomas Alva Edison invented a commercially viable electric bulb. This was exhibited in 1897



By using mechanical power in a battery, electric power was generated by providing the voltage. Edison proved that voltage is given in the ends of battery. The same was transferred into an electric motor which provided mechanical energy.



By extending Kinetoscope into 50 feet film strip, he made first talkie film by using electric motor and magnifying glass in 1891.

As a mark of respect to Edison on his death, the light of "Statue of Liberty" in New York was turned off. Except the road lights of Chicago and Broadway, all the lights in the city were turned off.

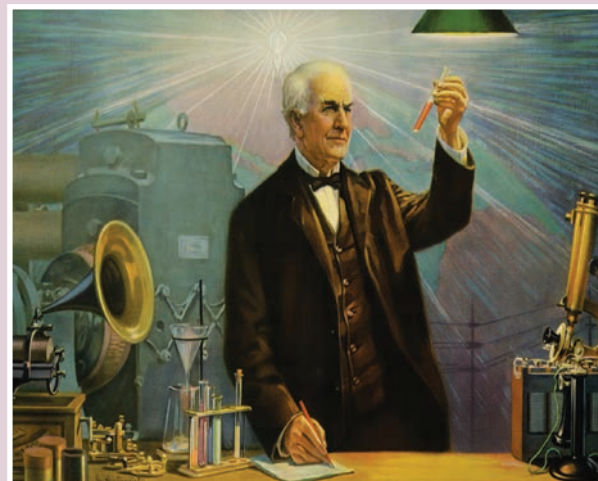

Edison was an American Scientist and Industrialist. He invented many instruments like Electric bulb, electric motor, gramophone and kinetoscope. He was known as for taking the world of darkness to brightness crossing all the obstacles in life.



3. The diaphragm becomes attracted to the electromagnet.
4. As the person on the other end of the line speaks, his voice cause the current in the circuit to change. This causes the diaphragm in the earpiece to vibrate, producing sound.

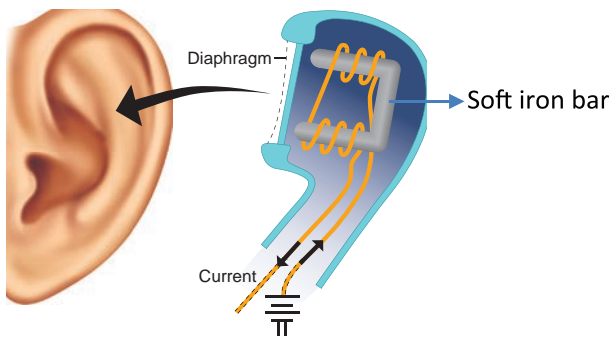

## 2.9. Chemical Effects of Electricity

Chemical reactions happens, when electricity passes through various conducting liquids. This is known as chemical effects of electricity. You will learn chemical effect of electricity in your higher classes.

### POINTS TO REMEMBER

- ❖ An electric current is a flow of electric charge or the amount of charge flowing through a given cross section of a material in unit time.
- ❖ Conventional current is in the direction opposite to electron flow.
- ❖ One ampere is defined as the flow of electric charge across a surface at the rate of one coulomb per second.
- ❖ An electric cell is something that provides electricity to different devices that are not fed directly or easily by the supply of electricity
- ❖ A dry cell is a portable form of a leclanche cell
- ❖ Batteries are a collection of one or more cells whose chemical reactions create a flow of electrons in a circuit
- ❖ The cell is the basic single electrochemical unit which converts chemical energy to electrical energy.
- ❖ Ammeter — An instrument for measuring the flow of electrical current in amperes. Ammeters are always connected in series with the circuit to be tested.
- ❖ Ampere (A) — A unit of measure for the intensity of an electric current flowing in a circuit. One ampere is equal to a current flow of one coulomb per second.
- ❖ Circuit — A closed path in which electrons from a voltage or current source flow. Circuits can be in series, parallel, or in any combination of the two.
- ❖ Current (I) — The flow of an electric charge through a conductor. An electric current can be compared to the flow of water in a pipe. Measured in ampere.
- ❖ Fuse — A circuit interrupting device consisting of a strip of wire that melts and breaks an electric circuit if the current exceeds a safe level.
- ❖ Conductor — Any material where electric current can flow freely. Conductive materials, such as metals, have a relatively low resistance. Copper and aluminum wire are the most common conductors
- ❖ Insulator — Any material where electric current does not flow freely. Insulation materials, such as glass, rubber, air, and many plastics have a relatively high resistance. Insulators protect equipment and life from electric shock.

- ❖ Parallel Circuit — A circuit in which there are multiple paths for electricity to flow. Each load connected in a separate path receives the full circuit voltage, and the total circuit current is equal to the sum of the individual branch currents.
- ❖ Series Circuit — A circuit in which there is only one path for electricity to flow. All of the current in the circuit must flow through all of the loads.
- ❖ Short Circuit — When one part of an electric circuit comes in contact with another part of the same circuit, diverting the flow of current from its desired path.
- ❖ One unit of coulomb is charge of approximately  $6.242 \times 10^{18}$  protons or electrons.
- ❖ The potential difference between any two points is the amount of energy needed to move one unit of electric charge from one point to the other.
- ❖ Electrical conductivity or specific conductance is the measure of a material's ability to conduct an electric current.
- ❖ Electrical resistivity is the property of a material that quantifies how strongly that material opposes the flow of electric current.
- ❖ The sources which produce the small amount of electricity for shorter periods of time is called as electric cell or electrochemical cells.
- ❖ Electrolytes : A substance that dissociates into ions in solution and acquires the capacity to conduct electricity. Sodium, potassium, chloride, calcium, and phosphate are examples of electrolytes.



## EVALUATION

### I. Choose the correct answers



- In the circuit diagram below, 10 units of electric charge move past point x every second. What is the current in the circuit?

- 
- a) 10 A    b) 1 A  
c) 10 V    d) 1 V

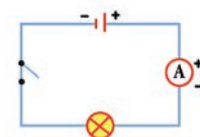

- In the circuit shown, which switches (L, M or N) must be closed to light up the bulb?

- a) switch L only  
b) switch M only  
c) Switch M and N only  
d) either switch L or switches M and N

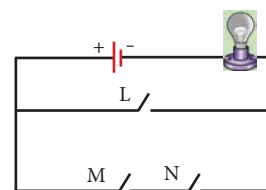

- Small amounts of electrical current are measured in milliamperes (mA). How many milliamperes are there in 0.25 A ?
- a) 2.5 mA                      b) 25 mA  
c) 250 mA                      d) 2500 mA
- In which of the following circuits are the bulb connected in series?

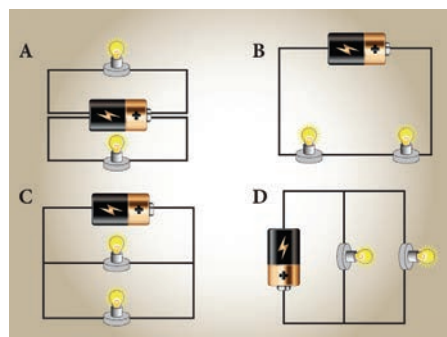

### II. Fill in the blanks.

- The direction of conventional current is ----- to electron flow.

2. One unit of coulomb is charge of approximately ----- protons or electrons.
3. ----- is used to measure the electric current.
4. In conducting materials electrons are ----- bounded with atoms.
5. S.I. unit of Electrical conductivity of a conductor is -----

### III. True or False – If False give the correct answer

1. Electron flow is in the same direction to conventional current flow.
2. The fuse wire does not melts whenever there is overload in the wiring.
3. In a parallel circuit, the electric components are divided into branches.
4. The representation of the electric current is A.
5. The electrical conductivity of the semiconductor is in between a conductor and an insulator.

### IV. Match the following

- |                              |   |  |
|------------------------------|---|--|
| 1. Cell                      | - | used to open or close a circuit                                |
| 2. Switch                    | - | safety device used in electric circuit                         |
| 3. Circuit                   | - | A complete path for the flow of an electric current            |
| 4. Miniature circuit Breaker | - | Reset by hand, circuit becomes complete once again             |
| 5. Fuse                      | - | A device which converts chemical energy into electrical energy |

### V. Analogy

1. Water : pipe :: Electric current :-----

2. Copper : conductor :: Wood : -----
3. Length : metre scale :: Current : -----
4. milli ampere: micro ampere ::  $10^{-3}A$  : -----

### VI. Assertion and Reason

1. Assertion (A) : Copper is used to make electric wires.

Reason (R) : Copper has very low electrical resistance.

Option:

- A. Both A and R are true and R is the correct explanation of A.
- B. Both A and R are true but R is NOT the correct explanation of A.
- C. A is true but R is false.
- D. A is false but R is true.
- E. Both A and R are false

2. Assertion (A): Insulators do not allow the flow of current through themselves.

Reason (R) : They have no free charge carriers.

- A. If both A and R are true and the R is correct explanation of A.
- B. If both A and R are true but R is not a correct explanation of A.
- C. If A is true and R is false.
- D. If both A and R are false.

### VII. Very short answer

1. What is the speed of electric current?
2. What is the S.I unit of electrical conductivity?
3. Name the device used to generate electricity.
4. Define fuse.
5. Name some devices that run using heat effect of electric current
6. Name few insulators.
7. What is a battery?

### VIII. Short Answer

1. Define an electric current.
2. Differentiate parallel and serial circuits.
3. Define electrical conductivity.

### IX. Long Answer

1. Explain the construction and working of an Telephone.
2. Explain the heating effect of electric current.
3. Explain the construction and working of a dry cell.

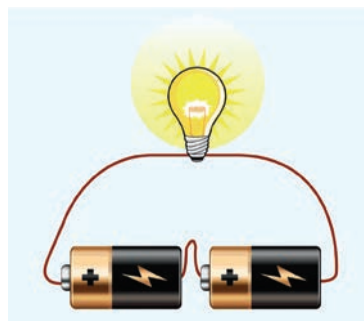

### X. Higher Order Question

A student made a circuit by using an electric cell, a switch, a torch bulb (fitted in the bulb holder) and copper connecting wires. When he turned on the switch, the torch bulb did not glow at all. The student checked the circuit and found that all the wire connections were tight.

- ❖ What could be the possible reason for the torch bulb not glowing even when the circuit appears to be complete?

### XI Picture based Questions

1. Three conductors are joined as shown in the diagram

The current in conductor RS is 10 A. The current in conductor QR is 6 A. What will be the current in conductor PR

- a) 4 A
- b) 6 A
- c) 10 A
- d) 16 A

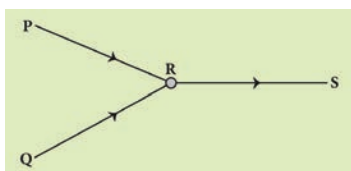

2. Draw the circuit diagram for the following series connection

3. Study the electric circuit below. Which of the following switches should be closed so that only two bulbs will light up
  - a) S1, S2 and S4 only
  - b) S1, S3 and S5 only
  - c) S2, S3 and S4 only
  - d) S2, S3 and S5 only

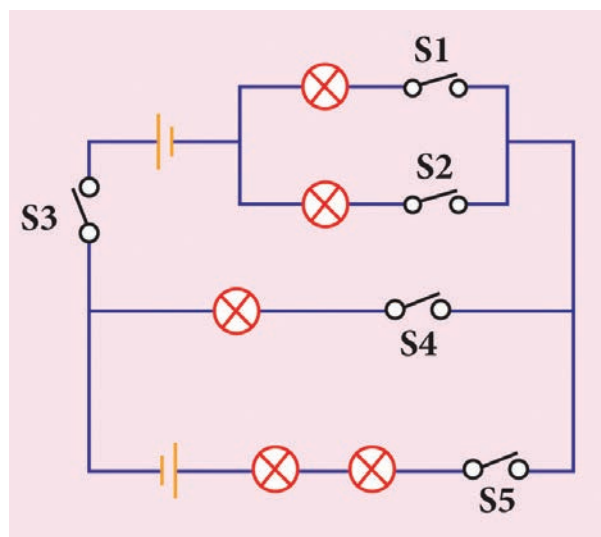

4. Study the three electric circuits below. Each of them has a glass rod (G), a steel rod (S), and a wooden rod (W).

In which of the electric circuits would the bulb not light up .

- a) A only
- b) C only
- c) A and B only
- d) A , B and C

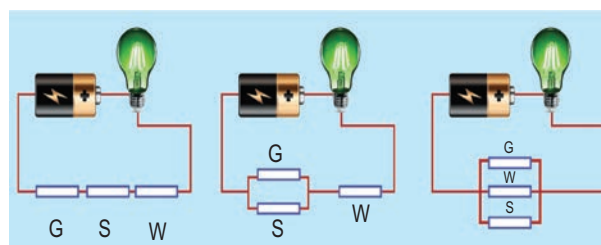



ICT CORNER

## ELECTRICITY

This activity helps the students to understand about the Parallel and series circuit

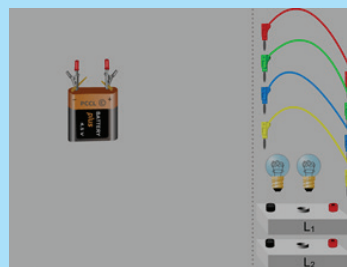

### PROCEDURE :

- Step 1:** Type the URL link given below in the browser or scan the QR code. A page opens with a battery , some cables, two sets for circuit and two bulbs.
- Step 2:** Ask the students to fix the wires to the battery and the circuit
- Step 3:** Let the students do it and understand the concept with different combinations

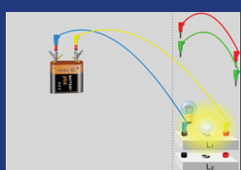

Step 1



Step 2

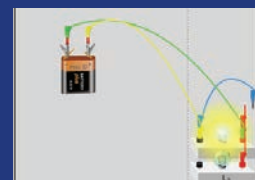

Step 3

### Electricity URL:

[http://www.physics-chemistry-interactive-flash-animation.com/electricity\\_electromagnetism\\_interactive/components\\_circuits\\_association-series\\_parallel.htm](http://www.physics-chemistry-interactive-flash-animation.com/electricity_electromagnetism_interactive/components_circuits_association-series_parallel.htm)

\*Pictures are indicative only

\*If browser requires, allow Flash Player or Java Script to load the page.



B351\_7\_SCIENCE\_EM



# Unit 3

## Changes Around Us

**Physical and Chemical Changes of Matter**

**Physical Changes of Matter**

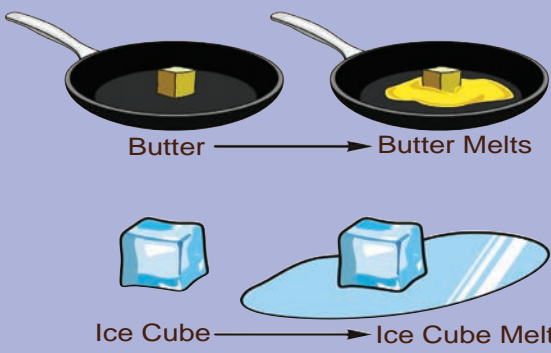

Butter → Butter Melts

Ice Cube → Ice Cube Melts

**Chemical Changes of Matter**

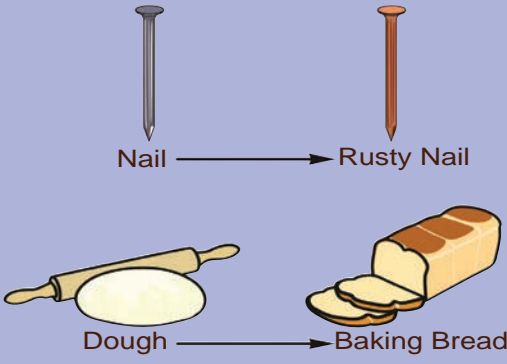

Nail → Rusty Nail

Dough → Baking Bread

### Learning Objectives

- ❖ To state the effect of heat on solid, liquid and gas and the associated changes in the arrangement of particles upon heating
- ❖ To differentiate physical change and chemical change on the basis of particle theory
- ❖ To involve in experiments crystallizing copper sulphate, melting ice, freezing water, sublimating camphor.
- ❖ To identify the process as a physical change or chemical change based on its characteristics
- ❖ To clarify the process of rusting, burning of paper, curdling of milk, reaction of baking soda with lemon juice
- ❖ To distinguish periodic and non-periodic changes
- ❖ To experience the endothermic and exothermic changes through simple activities



## Introduction

Changes take place around us all the time. A change refers to an alteration in physical properties or alteration in the composition of matter. For example, ice melts on heating, that is, it changes from a solid to liquid. On further heating, water starts evaporating; it changes from a liquid to gas. Here, there is a change in the physical state of the substance. Let us look at another change, that is, when objects made of iron are exposed to moist conditions, a reddish-brown new substance called rust forms on the surface of these objects. In this instance of rusting, there is change in the composition of the substance. Thus, the change involves an alteration in the properties such as colour, texture and the state of the substance since there is formation of a new substance.

Let us go for another set of example. Heat a cup of water and a paper. The water upon heating become just hotter and hotter and at some point

will become water vapour. It remains water at all times; that is, water remains the same, only its volume changes and hence it is called as physical change. Whereas in case of burning of paper, changes to carbon dioxide and other substances. Now we cannot get back the paper after burning. As there is a change in the chemical nature, it is called as chemical change.

When you mix sugar in water, is it a chemical change or physical change?

Look at the following list. Identify the physical and chemical changes and fill in the given table.

(rusting of iron, digestion of food, boiling egg, rotting banana, mixing sand and water, chopping wood, crushing a can, mixtures of different coloured buttons, burning of wood)

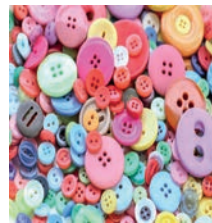

Physical Changes	Chemical Changes

In class six, we read that matter is classified as solid, liquid and gas based on the physical state. We know that matter is made up of tiny particles, atoms and molecules; particles are in constant and random movement. Let us have a look at the summary of the characteristics of solid, liquid and gas.

When the arrangement of the particles in a substance change for any reason (applying pressure, altering temperature and other different reasons) the physical state of the substance gets changed.

Let us see what happens when we apply heat to the substances.

### 3.1 Effect of heat on solid, liquid and gases



Upon heating, particle arrangement within the state of matter gets disturbed. The disturbance is seen either as expansion or contraction.

When heated or cooled, the object may expand or contract, but the mass remains the same. That is, the number of particles that was inside the object does not undergo any change, only the arrangement of the particle changes. When a glass of water is heated, its volume increases and if a glass of water is cooled its volume decreases.

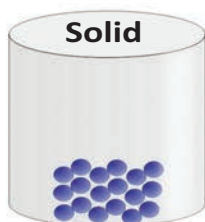

**In which particles are very close together.**

**Particles are arranged in a fixed regular pattern.**

**Particles can vibrate about their fixed positions.**



**In which particles are close together.**

**Particles are not arranged in a fixed regular pattern.**

**Particles are able to slide past one another.**

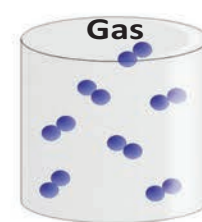

**Particles are far apart from each other.**

**Particles are not arranged in a fixed regular pattern.**

**Particles move freely over long distances.**

Such changes where there is change in volume but mass remaining the same are called physical changes and they can be pictorially depicted as follows:

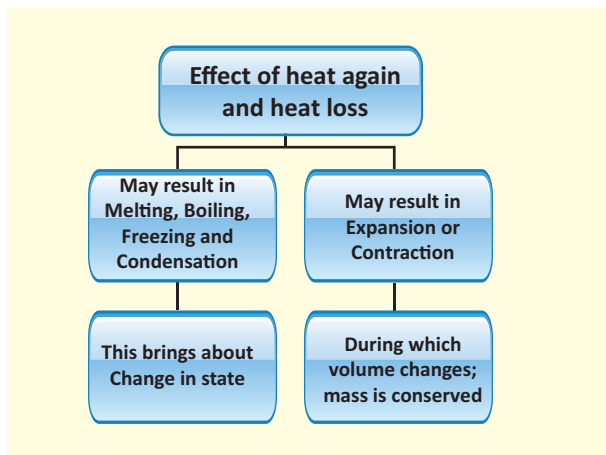

There are other possibilities that can occur upon heating the solids, liquids and gases. The possible changes are due to melting, boiling, freezing and condensation during which there is change in the physical state of the particles of the matter. Let us discuss about them in detail in a short while.

Let us now see some physical changes and the underlying reasons as why they are simply physical changes.

### 3.2 Physical changes



Physical changes are the changes in which only physical properties of a substance undergo a change and there is no change in its chemical composition. There is no new substance formed in a physical change. Physical properties include lustre, malleability (flexibility), and ductility (ability to be drawn into a thin wire),

density, viscosity, solubility, mass, volume and so on. Any change in these physical properties is referred to as a physical change. For example, when a rubber band is stretched, it elongates. However, when then stretching is stopped, the rubber band comes back to its original state and shape. In this example, there is no new substance formed but the rubber band remains the same before and after elongation.

#### 3.2.1 Characteristics of a physical change

A physical change has following characteristics:

- ❖ During a physical change, no new substances are formed. In a physical change, the chemical properties of a substance do not change. For example, when ice cube melts, water is formed. In this change, there is no new substance, but water is same both in ice and in water.
- ❖ A physical change is usually temporary and reversible in nature. For example, when water is heated, water vapours are formed, once water vapours are cooled, water can be obtained again.
- ❖ In a physical change, the chemical properties of a substance do not change. For example, when a piece of gold is melted, its chemical composition remains the same in the solid form and also in the liquid form.
- ❖ In a physical change, the physical properties such as colour, shape and size of a substance may undergo a change. For example, cutting of vegetables and inflating a balloon are some examples of physical changes in which size and shape of a substance undergoes a change. we know it is not



### 3.3 Changes of state

Change of state of a substance is one of the major physical changes we encounter in daily lives. We have read about simple changes of physical state such as melting of ice in our previous classes.



The following are some of the changes of state:

from Solid → to Liquid is Melting

from Liquid → to Gas is Vaporization

from Liquid → to Solid is Freezing

from Gas → to Liquid is Condensation

from Solid → to Gas is Sublimation

Melting, vaporization, and sublimation occur when heated and hence it is called as endothermic process. In an endothermic process, the speed of the molecules is increased hence they move faster.

In contrast, such as in freezing and condensation, heat is removed, resulting in the decreasing the speed of the molecules causing them move slower. Such processes are called as exothermic process.

In the next section we will look at each of these physical changes.

#### 3.3.1 Melting

You have seen a puddle of water getting pooled around the glass of ice-cream or a glass

of ice cubes when it is kept in room temperature. The ice cubes / ice-cream melt. Right! Can you give reason for that? The ice kept in the beaker receives heat from the surrounding air, to melt and form water.

### ACTIVITY 1

#### Melting of ice and freezing of water

Though ice and water look different, they are both made of water molecules. This means that no new substance is formed during the melting of ice, only a change of state from solid to liquid takes place during the melting of ice. So, the melting of ice to form water is a physical change.



The change which occurs during the melting of ice to form water can be reversed easily by freezing the water to form ice again by keeping a beaker of water in the freezer zone of a refrigerator.

Thus we can find that

Solid  $\xrightarrow{\text{heating}}$  Liquid

Liquid  $\xrightarrow{\text{cooling}}$  Solid

Melting is the changing of a solid into its liquid state and it happens by heating, whereas Freezing is the changing of a liquid into its solid state and it happens by cooling.

#### 3.3.2 Vapourization

Look at a kettle kept on the fire. The bubbles form and the liquid water becomes



water vapour, if you heat it sufficiently.

However, when you put a wet cloth to dry, the water evaporates into air, leaving the clothes dry.

That is there are two types of vaporization: boiling and evaporation, the first one is by heating and the second type of vapourization is natural.

Boiling is the process of conversion of a liquid into vapours on heating. In gaseous state, only the arrangement of molecules changes, there is no change in their chemical composition. So, boiling is a physical change.

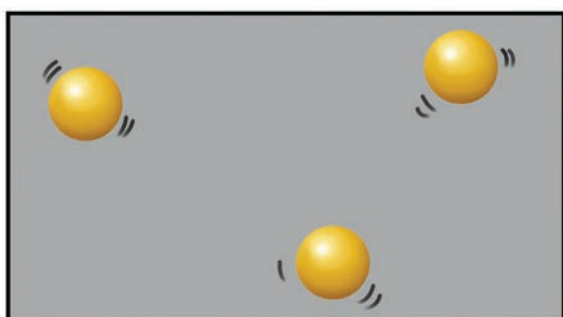

Particles of a gas

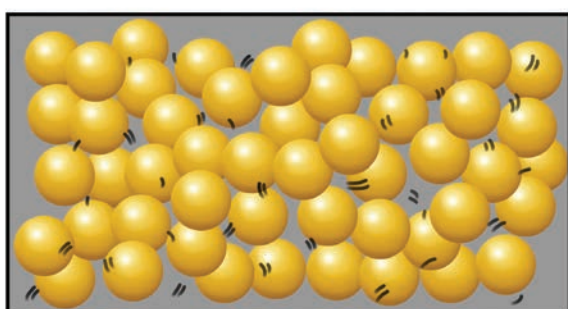

Particles of a liquid

Upon heating a liquid, the particles gain energy and vibrate more vigorously. When the particles possess enough energy, they overcome the strong forces of attraction between one another. The particles break free from one another and move randomly. For example, when liquid water is heated to  $100^{\circ}\text{C}$ , it boils to become steam. Boiling occurs when the

boiling point is reached.

The liquid changes to its gaseous state.

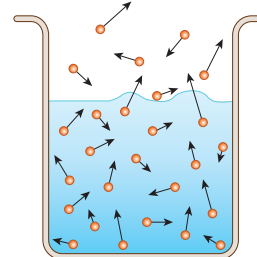

### Evaporation

Take a glass of water. All the water molecules are moving here and there at different velocities (shown as arrows of different lengths). Some of the molecules, especially at the surface, could be moving in a direction away from the liquid, and have adequate energy to overcome the attractive force (surface tension) of the liquid, then that molecule will escape into the air. Thus slowly and steadily the water molecules escape, or said to evaporate, and the water level in the glass decreases as the time passes. Note that the temperature of the water did not rise to the level of boiling point of water. Nor were there any bubbles formed like boiling.

Evaporation is the technique used to separate dissolved solids from a solid-liquid mixture. This is the technique used to extract salt from sea water in salt pans. Shallow level of sea water is impounded. Slowly the water evaporates due to action of Sun. Ultimately salt deposits over the ground we can understand. Evaporation makes use of the fact that the solvent in a solution can vapourise at any temperature, leaving behind a residue of the solid that was dissolved in the liquid.

From drying clothes to drying fish, evaporation is used.

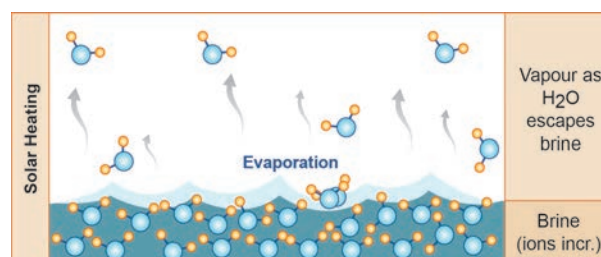

### Factors affecting the rate of evaporation

## ACTIVITY

### Activity 2

You must be remembering an activity done in Class six, in which we have taken two same shaped glasses and fill them with equal amount of water from same tap. We kept one under the hot sun and other under the shadow. After three to four hours, we saw that there is difference in water levels. The one kept in the hot place witness more evaporation compared to the one in shade. From this we can conclude that higher the temperature, the rate of evaporation will be more. As the temperature increases, more molecules are able to break free from the surface. Thus the rate of evaporation increases with rising temperature.

### Activity 3

Take two pans, one wide and another narrow. Fill hot water in both to the same depth. Keep them in open. Observe after one to two hours. The pan that is wide has cooled more than the narrow one. That is more the surface area; the rate of evaporation is more.

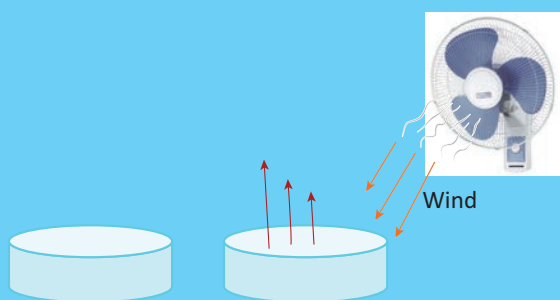

From this, can you guess why we unfurl the clothes while putting them to dry, rather than just drape them over the cloth line?

Greater the surface of conversion of a liquid, more molecules are available for evaporation.

### Activity 4

Take sugar solution in a shallow, broad bowl. Place the bowl in hot sun for a few hours. See that the bowl does not get any disturbance for the whole day. You can see that the solvent in the sugar solution evaporates leaving the sugar crystals in the bowl.

Evaporation is a slow process and occurs only at the surface of the liquid.

### 3.3.3 Freezing

Water in the freezer compartment of a refrigerator gets cooled and solidifies to form ice. In this case, the liquid water changes into solid water called ice.

Only a change in state (from liquid to solid) takes place during the freezing of water to form ice, but no new substance is formed. So, the freezing of water is a physical change.

Upon cooling a liquid, the particles loose energy and vibrate less vigorously. When the particles possess less energy, they can experience strong forces of attraction between one another. The particles move closer to each other and movement of particles is also restricted. For example, when liquid water is cooled to  $0^{\circ}\text{C}$ , it freezes to become ice. Freezing occurs when the freezing point is reached. The liquid changes to its solid state.

The arrangement of particles in liquid and solid are diagrammatically represented as follows:

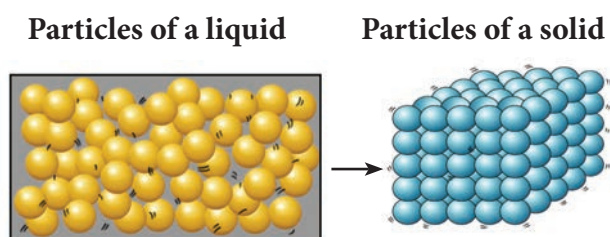

### 3.3.4 Condensation

We would have observed that the plate that covers the cooked food items have water droplets inside. Why?

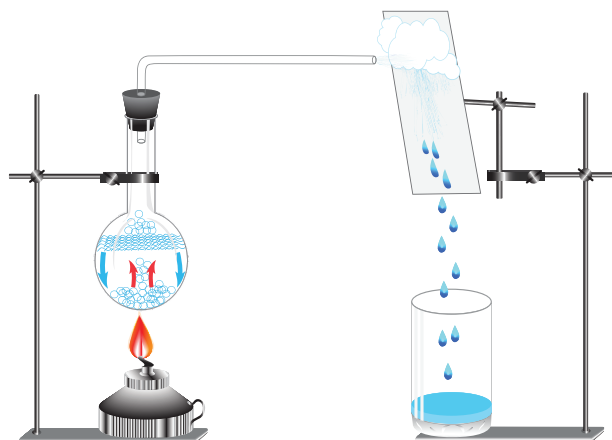

The water vapour emerges from the hot food and goes up. The plate covering the food item is in relative less temperature than the hot food. Thus the more energetic molecules loose energy once they touch the cooler plate. As the molecules lose heat, they lose energy and slow down. They move closer to other gas molecules. Finally these molecules collect together to form a liquid. Condensation happens when molecules in a gas cool down.

In class six, you learnt about water cycle in which you already know how the clouds are formed from water vapour. Water vapour

condenses to form clouds.

Condensation is the conversion of gas into its liquid state. The liquid obtained after condensation can be converted back into gas on heating. So, condensation is also a physical process. During this process, only the arrangement of molecules changes from the gaseous state to liquid state. So, condensation is a physical change.

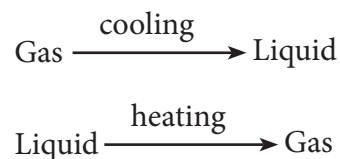

**Condensation** is the changing of a gas into its liquid state and it happens by cooling, whereas **Evaporation** is the changing of a liquid into its gas state and it happens by heating.

### 3.3.5 Sublimation

We have seen camphor being burnt at home, kept in rooms to prevent entry of mosquitoes. Have you ever noticed camphor becoming liquid at any point of time? ..... It will not.

There are certain solid substances like camphor, naphthalene that get converted into gas directly upon heating without becoming liquid. **This process in which a solid is converted directly into gas is called sublimation.**

In each of the above said processes, there is a change of state due to change in temperature. But there is no change in chemical composition. By changing the temperature all these changes can be reversed. We know that change of a physical state is only a physical change. So,

evaporation, boiling, condensation, melting and freezing are all physical processes

### ACTIVITY 5

#### Sublimation

Take some camphor in a porcelain dish and cover it with a clean glass funnel. Close the mouth of the funnel with small amount of cotton wool. Heat the contents in the dish. can you see that camphor changes into vapour state without becoming liquid.

Ammonium chloride is another substance that undergoes sublimation.

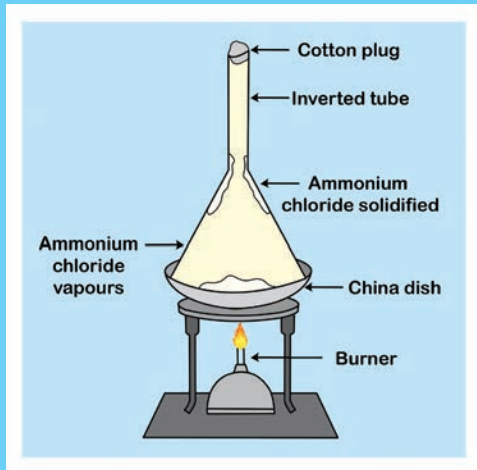

### 3.3.6 Crystallization

Though not mentioned earlier, crystallization is also a special form of physical change. The soluble impurities get removed from certain solids by crystallization. The process of cooling a hot, concentrated solution of a substance to obtain crystals is called crystallization.

We also know that sea-water contains salts dissolved in it and the salt can be separated from sea-water by the process of evaporation. The process of evaporation is not a good technique because the soluble impurities do not get removed in the process of evaporation.

### ACTIVITY 6

#### Crystallizing copper sulphate

Take about 100ml of water in a beaker. Heat the water over a burner till it boils. Add impure copper sulphate to the hot water with constant stirring. Continue to add copper sulphate till the solution takes up the added copper sulphate, that is, the added copper sulphate will not dissolve anymore. Filter the contents on a glass plate and allow it to cool. You could see crystals of copper sulphate in a few hours.

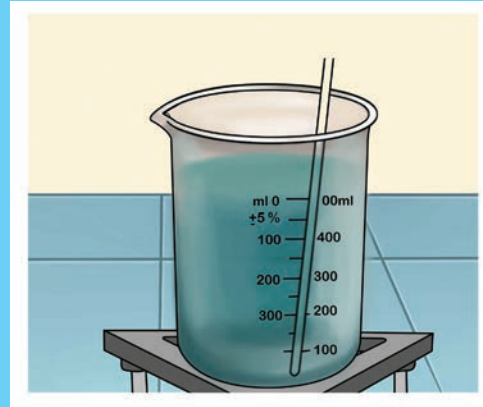

Further the crystals of salts obtained by the process of evaporation are small. The shape of crystals cannot be seen clearly. So the solid substances are usually purified by the process of crystallization. Large crystals of pure substances can be obtained from their solutions by the process of crystallization. **Crystallization is a method of separation as well as a method of purification.**

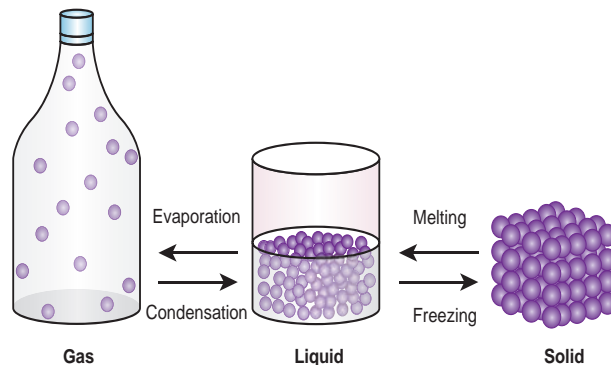

### 3.4 Chemical changes

Changes that occur with the formation of new substance with different chemical composition or transformation of a substance into another substance with the evolution or absorption of heat or light energy are termed as chemical changes. Rusting of iron, burning, curdling of milk, reaction of baking soda with lemon juice, fermentation are some examples of chemical changes.

Chemical changes are very important in our lives. All the new substances which we use in various fields of our life are produced as a result of chemical reactions. Some of the examples of the importance of chemical changes are given below:

- Metals are extracted from their naturally occurring compounds called 'ores' by a series of chemical changes.
- Medicines are prepared by carrying out a chain of chemical changes.
- The materials such as plastics, soaps, detergents, perfumes, acids, bases, salts etc are all made by carrying out various types of chemical changes.
- Every new material is discovered by studying different types of chemical changes.

In addition to new products, the following may also accompany a chemical change:

- Heat, light or any other radiation may be given off or absorbed.
- Sound may be produced
- A change in smell may take place (or) a new smell may be given off.
- A colour change may take place.
- A gas may be formed.

Explosion of a firework is a chemical change. We know that such an explosion produces heat, light, sound and unpleasant gases that pollute the atmosphere. That is why we are advised not to play with fireworks.

When food gets spoiled, it produces a foul smell. Shall we call this change as a chemical change? ..... Discuss in the class. Give your reflections.

You must have noticed that a slice of an apple acquires a brown colour if it is not consumed immediately. Colour of the potato remains the same when stored in water but there is change in colour with the piece kept in air. Look at the cut brinjal kept in air. The change of colour in these cases is due to the formation of some new substances which you will learn in higher classes. Are these not chemical changes?

#### Try yourself

Cut a fresh slice of potato and brinjal and keep it away for sometime.

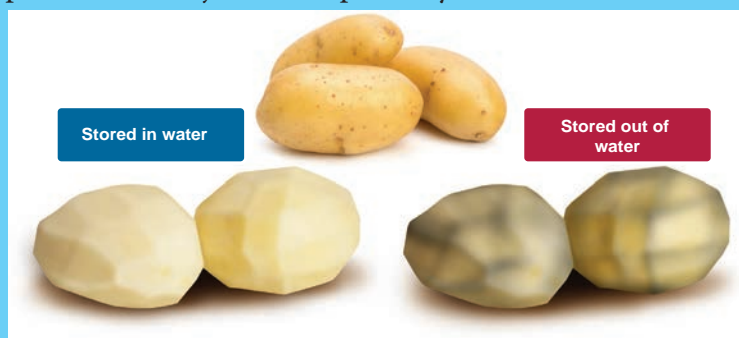



**Discuss and give your answer**

You know that plants produce their food by a process called photosynthesis.

Can we call photosynthesis a chemical change?

**3.4.1 Rusting of iron**

In class six, we have already studied that rusting is an example of a chemical change. Now, shall we read why the process of rusting is called a chemical change.

**The Iron Pillar at Delhi**

Amazingly there is an iron that did not rust!

There is an iron pillar at the Qutub complex in Delhi which is more than 1600 years old. Even after such a long period, the iron pillar kept in open spaces has not rusted at all. This shows that Indian scientists made great advances in metal making technology even at 16th century which enabled them to make this iron pillar having the quality of great rust resistance.



Rusting is one change that affects iron articles and slowly destroys them. Since iron is used in making bridges, ships, cars, truck bodies and many other articles, the monetary loss due to rusting is huge. The process of forming rust is represented as follows:

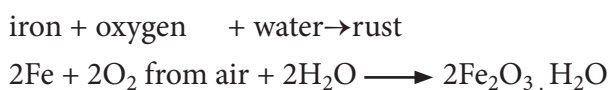

For rusting to take place both oxygen and water (or even water vapour) is essential. In fact, if the content of moisture in air is high, the air is said to be more humid and eventually rusting is faster.

How can we prevent rusting?

Iron articles can be prevented from making contact with oxygen, water/water vapour. A simple way is to apply a coat of paint or grease. These coats should be applied regularly to prevent rusting.



Another way of preventing rusting is to deposit a layer of a metal like chromium or zinc on iron. This is called galvanization and you will learn about this detail in higher classes.

**3.4.2 Burning**

We have already studied that burning of paper is a fast change. Burning a piece of paper gives entirely new substances such as carbon-dioxide, water, water vapour, smoke and ash. Heat and light are also given out during the burning of

**ACTIVITY 7**

Take a small piece of magnesium ribbon and clean it by rubbing its surface with a sand paper. Hold the magnesium ribbon at one end with a pair of tongs and bring its other end over the flame of a burner.

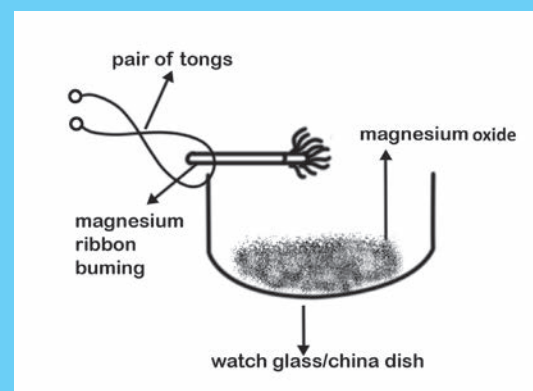

paper. We cannot combine the products of burning of paper to form the original paper again. So, it is a permanent change. Now, shall we perform an activity of burning a piece of magnesium ribbon and find what type of change is it?

### What do you observe?

You can see that the magnesium ribbon starts burning with a dazzling white light. Hold the burning magnesium ribbon over a watch glass so that the powdery ash being formed by the burning of magnesium collects in the watch glass.

When magnesium ribbon burns in air, then the magnesium metal combines with the oxygen of air to form a new substance called magnesium oxide.

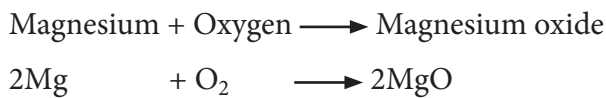

Magnesium oxide compound appears as a white powdery ash.

The burning of magnesium ribbon is a chemical change, because a new substance, magnesium oxide, is formed during this change.

### 3.4.3 Curdling of milk

We know that curdling of milk is an example of irreversible change since we cannot get back the milk after curdling occurs. It is also called as a chemical change. Shall we clarify the process of curdling?

Curdling is a process in which liquid gradually turns into solid, forming clumps along the way. Take hot milk in a pan and add few drops of curd, in few minutes milk curdles forming lumpy solid masses. We can even add lemon extract to the hot milk to effect curdling immediately, but the taste and texture of the

curd will not be the same as that of the curdling occurring in a few hours. You can try to taste the curd formed by immediate curdling and gradual curdling.

### 3.4.4 Fermentation

In class six, we saw an example that preparation of batter to produce idly is an example for irreversible change.



Fermentation is the process in which microorganisms such as yeast and certain bacteria break down sugar solution into alcohol and carbon-di-oxide.

It is an irreversible process as the alcohol formed cannot be turned back into sugar. Thus, fermentation is a chemical change.

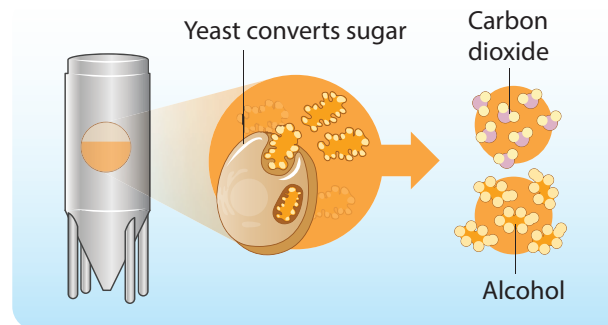

Louis Pasteur (1822-1895), a French chemist and microbiologist was the first person to describe the process of fermentation.



He described that fermentation occurs in the absence of air and in the presence of micro organisms such as yeast. He discovered the cure for rabies.

### 3.4.5 Chemical reaction of baking soda with lemon

Baking soda is sodium hydrogen carbonate and lemon juice contains citric acid. So, when these two substances are mixed together, then a chemical change takes place between sodium hydrogen carbonate and citric acid to form three new substances: sodium citrate, carbon-di-oxide and water. The chemical change can be written in the form of a word equation as follows:-

Sodium hydrogen carbonate + citric acid →  
sodium citrate + carbon dioxide + water

#### ACTIVITY 8

When baking soda and lemon juice are mixed together, then bubbles of carbon-di-oxide are formed along with the formation of some salt and water. Take 10 ml of lemon juice and add pinch by pinch of baking soda to it. Actually when we mix baking soda with lemon juice, we will hear a hissing sound when bubbles of carbon-di-oxide coming out and rising in the reaction vessel.

### 3.5 Conditions needed for a chemical change

We know that firing of crackers is a chemical change. Some crackers explode only when thrown against a wall or struck with a hard substance. Thus, we could see that **change in pressure** may also bring about a chemical change.

When lemon juice is mixed with soda water, they produce brisk effervescence which is otherwise not possible when they are separate.

So we can say that many chemical changes occur only when the **substances are made to physically contact with each other.**

We have tasted raw rice and cooked rice, Have not we? They are different in their taste. Cooking is a process that is involved in the stated example, wherein rice is boiled with sufficient water. It is the heat and the water that had brought the change in texture and taste of the rice before and after cooking. Thus we can say that **heating** is a condition needed for a chemical change to occur.

We know the use of vanaspathi in cooking vanaspathi is obtained from vegetable oils by addition of hydrogen to the oils. nickel, platinum or palladium are used as catalyst during the process of hydrogenation of oils.



Catalysts are substances that speed up the process of a chemical change and it will not undergo any change during the course of the reaction. For example, yeast acts as the catalyst in the fermentation of sugar. You will learn more about catalyst in your higher classes.

Water is a chemical compound that remains as water when undisturbed. But if a few drops of an acid is added to water and subjected to electrolysis by passing electric current, it decomposes into hydrogen and oxygen. So, we can understand that **electric current** is also a condition that is needed for effecting a chemical change.

Thus we can conclude that physical contact of the substances, heat, light, electricity, applying pressure are some of the different conditions needed for chemical changes to occur.

### 3.6 Indicators of a chemical change

Take some broken pieces of egg shell in a test tube and add lemon juice to it. You could see bubbles of carbon-di-oxide evolving in the test tube. This is because of the chemical change between the two. Hence, we can say that evolution of bubbles serve as an indicator that of a chemical change.

When water is added to quicklime (calcium oxide) there will be evolution of lot of heat along with the formation of slaked lime (calcium hydroxide). This is a chemical change and it is indicated by the evolution of heat when the reaction sets in between quicklime and water.

Every day we cook food stuffs and clean the empty cooking utensils. Suppose when we leave the cooked utensils with some cooked food and leave them without washing for a day, we could sense a foul-smell coming from the vessels the next day. This is because the food stuff had become rotten and produces a foul-smell. Here spoilage of food is a chemical change and it is indicated by the foul smell. So, change of odour is also an indicator of a chemical change.

When an iron nail is kept in water for a few days and taken out, the nail will become reddish brown in colour indicating that it has rusted. We know that rusting is a chemical change and it is indicated by a change in colour of the iron nail.

We know that hot milk curdles to form white lumps of curd when mixed with lemon juice. A lump of curd is the precipitate that is obtained by the chemical reaction between hot milk and lemon juice. So, formation of precipitate is also an indication of a chemical change.

To conclude, there can be evolution of bubbles, evolution of heat, change of odour, change in colour or formation of a precipitate that serve as indicators for us to understand that a chemical change had taken place.

### 3.7 Exothermic and Endothermic chemical changes

Just as the physical change, Chemical reaction will be either endothermic or exothermic.



#### ACTIVITY 9

Ask a student to stretch both hands, put a pinch of soap powder in one hand and a pinch of glucose in the other hand. Add a few drops of water to soap powder and ask how the student feels upon adding water. Now add a few drops of water to the glucose at the other hand. Now ask the student how he /she feels on adding water, What is the feeling when water is added to glucose?

.....  
What is the difference when water is added to soap powder and when water is added to glucose?  
.....

In this activity, the student reported that he / she felt the warmness in the palm when water is added to soap powder. Right! We saw that the burning of magnesium ribbon gives out heat and light. Similarly, burning of wood also releases heat and light. Such changes in which heat is released are known as exothermic changes.

# Endothermic Exothermic

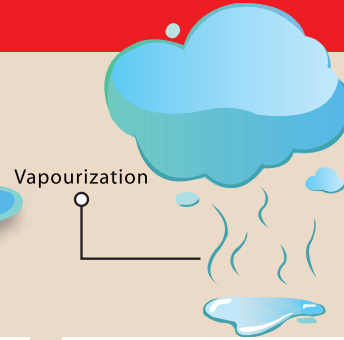
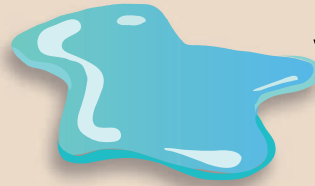
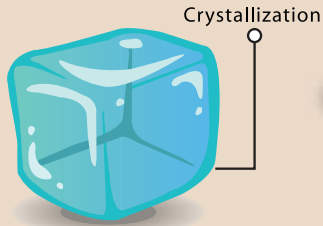

## Particles of Solids

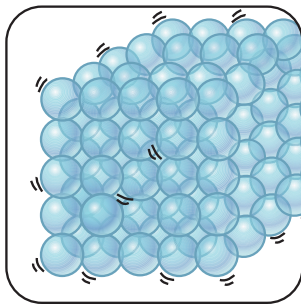

↓  
heated  
↓

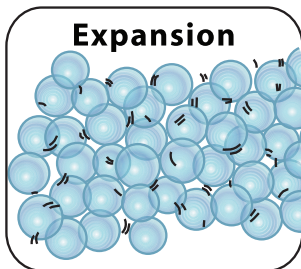

↓  
Becomes Liquid  
**MELTING**



## Particles of Liquids

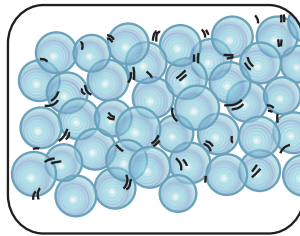

↓  
cooled  
↓

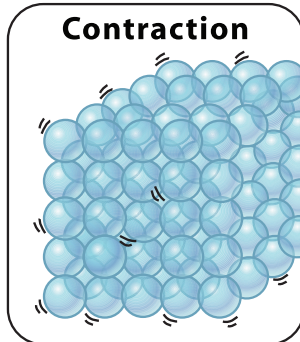

↓  
Becomes Solid  
**FREEZING**



## Particles of Gas

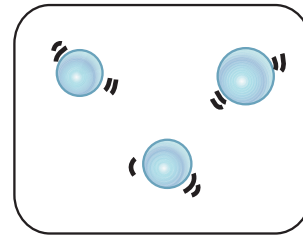

↓  
cooled  
↓

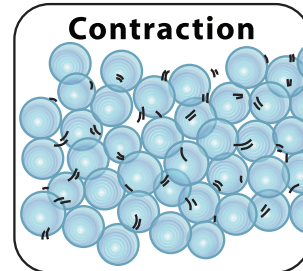

↓  
Becomes Liquid  
**CONDENSATION**







PERIODIC CHANGE

NON-PERIODIC CHANGE



### MIXING EGG SHELL OR BAKING SODA WITH LEMON JUICE



### RUSTING OF IRON

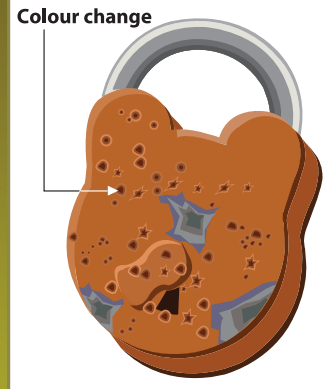

### BURNING OF MAGNESIUM RIBBON

Formation of new product:  
**Magnesium oxide**

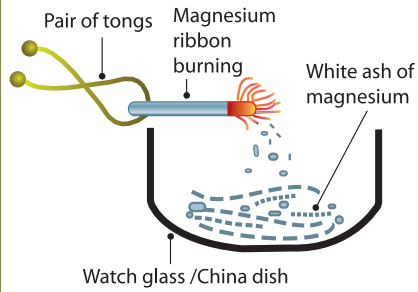

### MIXING QUICK LIME WITH WATER

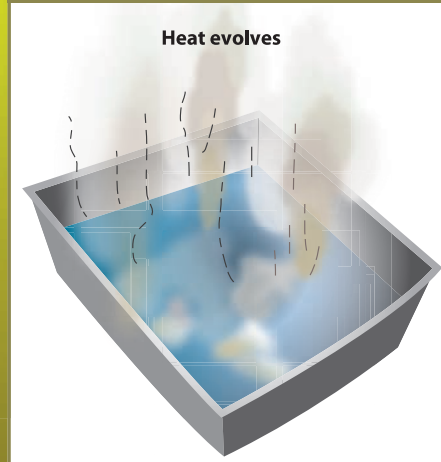

### CURDLING OF MILK

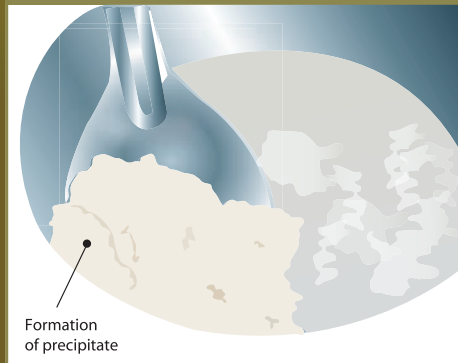

### THUNDERSTORM



There are some changes in which heat is absorbed. For example, water absorbs heat when it evaporates to form water vapours. Similarly ice absorbs heat when it melts to form water. Such changes in which heat is absorbed are known as endothermic changes. Dissolution of glucose in water is also an endothermic change.

### 3.8 Periodic and non-periodic change

Depending on whether or not a change repeats itself after a definite period of time, it can be classified as periodic change or a non-periodic change.

#### Periodic changes

Changes that repeat themselves after a definite interval of time are called **periodic changes**.



Rotation and Revolution of earth, beating of the heart, clock striking every hour, motion of the seconds-hand / minute-hand / hour-hand of a clock are some examples of periodic changes.

Every year we observe that seasons changes. We go from rains to winter and winter to summer and so on.

- ❖ What types of clothes are worn in winter?  
-----
- ❖ What are the clothes that we wear in summer? -----

If the winter season changes into summer, we observe change in the texture type of clothes we wear. We wear woolen clothes in winter and cotton clothes in summer. Similarly, we observe that the winter season is cool and summer season is hot. In winter, duration of night is longer than in summer. We take cold drinks in summer but prefer hot tea, coffee or milk in winter. These changes that we observe show the change of seasons.

The seasons and changes in weather occur because earth rotates on its fixed axis. Changing seasons are almost periodic in nature.

#### Non-periodic changes

Changes that do not repeat themselves after a definite interval of time and occur randomly are called **non-periodic changes**. Eruption of a volcano, occurrence of an earthquake, a streak of lighting flash across the sky during a thunderstorm, running of a batsman between the wickets, movement of legs while dancing are a few examples of non-periodic changes.



#### POINTS TO REMEMBER

- ❖ Particle arrangement within the state of matter gets disturbed upon heating. The disturbance is seen either as expansion or contraction.
- ❖ A process in which liquid changes into vapour on heating is called evaporation.
- ❖ A process in which solid changes into liquid on heating is called melting or fusion.
- ❖ A process in which gas changes into a liquid is called condensation.
- ❖ A process in which liquid changes into solid is called freezing.
- ❖ Physical changes are the changes in which only physical properties of a substance undergo a change and there is no change in its chemical composition.
- ❖ Solid substances are usually purified by the process of crystallization.
- ❖ Evaporation is the technique used to separate dissolved solids from a solid-liquid mixture.
- ❖ Certain solid substances like camphor, naphthalene get converted into gas directly without becoming liquid upon heating by sublimation.

- ❖ Changes that occur with the formation of new substance with different chemical composition or transformation of a substance into another substance with the evolution or absorption of heat or light energy are termed as chemical changes.
- ❖ Changes that repeat themselves after a definite interval of time are called periodic changes.
- ❖ Changes that do not repeat themselves after a definite interval of time and occur randomly are called non-periodic changes.
- ❖ Changes in which heat is absorbed are known as endothermic changes.
- ❖ Changes in which heat is released are known as exothermic changes.



### Evaluation



#### I. Choose the best answer

1. When a woolen yarn is knitted to get a sweater, the change can be classified as \_\_\_\_\_.
  - a. physical change
  - b. chemical change
  - c. endothermic change
  - d. exothermic change
2. \_\_\_\_\_ of the following are endothermic changes.
  - a. Condensation and melting
  - b. Condensation and freezing
  - c. Evaporation and melting
  - d. Evaporation and freezing
3. The chemical change is \_\_\_\_\_.
  - a. water to clouds
  - b. growth of a tree
  - c. cow dung to bio-gas.
  - d. ice-cream to molten ice-cream.
4. \_\_\_\_\_ is an example of a periodic change.
  - a. Earthquake.
  - b. Formation of rainbow in sky
  - c. Occurrence of tides in seas.
  - d. Showering of rain
5. \_\_\_\_\_ is not a chemical change.
  - a. Dissolution of ammonia in water
  - b. Dissolution of carbon-di-oxide in water
  - c. Dissolution of oxygen in water
  - d. Melting of polar ice caps

#### II. Fill in the blanks

1. Filling up a balloon with hot air is a \_\_\_\_\_ change.
2. Stretching gold coin into a ring is a \_\_\_\_\_ change.
3. Opening a gas cylinder knob converts \_\_\_\_\_ fuel into \_\_\_\_\_ fuel. This is an example of \_\_\_\_\_ change.
4. Spoiling of food is a \_\_\_\_\_ change.
5. Respiration is a \_\_\_\_\_ change.

#### III. True or False. If false, give the correct answer.

1. Cutting of cloth is an example of a periodic change.
2. Taking a glass of water and freezing it by placing it in the freezer is a chemical change.
3. A bean plant collecting sunlight and turning it into bean seeds is an example of physical and non-periodic change.
4. If the chemical properties of a substance remain unchanged and the appearance or shape of a substance changes it is called a periodic change.
5. Tarnishing of silver is an example of endothermic change.

**IV. Match the following**

A	B	C
1. Melting	Change of state from liquid to solid	Ticking of clock
2. Condensation	Change of state from liquid to gas	Formation of ice cube
3. Evaporation	Change of state from solid to liquid	Collecting flowers
4. Freezing	Change of state from gas to liquid	Ice cube to water
5. Periodic change	Occurs at irregular time intervals	Water to steam
6. Non-periodic change	Occurs at regular time intervals	Steam to water drops

**V. Classify the following changes as physical and chemical changes**

A rough piece of wood is sanded and polished resulting in change in texture, Rusting of a iron nail, Painting the grill, Bending a paper clip, Pounding silver into thin plate, Rolling the chappathi dough into thin wire, Occurrence of day and night, eruption of volcano, burning of matchstick, dosa from the batter, blinking of eyelids, occurrence of a thunderstorm, rotation of the earth, formation of eclipses.

Physical changes	Chemical changes

**VI. Analogy**

- Physical Change: Boiling::Chemical Change: \_\_\_\_\_.
- Wood to saw dust:\_\_\_\_\_ :: Wood to Ash: Chemical change
- Forest fire: \_\_\_\_\_ change::Change in period in a school: periodic change

**VII. Very short answer type question**

- State two examples of periodic changes.
- Mention any two exothermic reactions.
- Cold milk is heated and it becomes hot. Which type of change it is?
- What type of change is artificial ripening of fruit?

- What type of change is colouring of a paper?
- Growing of nails is a periodic change. Why?
- What type of energy changes is associated when ice melts?

**VIII. Short answer type question**

- Distinguish physical and chemical changes.
- How can a change occur in a substance?
- Can you suggest a method to collect water from sea water?
- Is solar eclipse a periodic change? Give your reason.
- What is the difference between dissolution of sugar and burning of sugar?

**IX. Long answer type question**

- Explain the following statement: Digestion is a chemical change.
- How the iron blade is fixed into a wooden handle in tools used to dig the soil?

**X. Higher order Thinking questions**

- Peeled and unpeeled banana does not look the same. Does that mean peeling banana is a chemical change?
- A very hot glass on putting in cold water cracks. What does this change indicate?
- Boiling of water is a physical change; but boiling of egg is a chemical change. Why?

**XI. Assertion – Reason type question**

- Assertion: The explosion of fire cracker is a physical change.

Reason: A physical change is a reversible change.

- a. Both A and R are true and R is the correct explanation of A.
  - b. Both A and R are true but R is not the correct explanation of A.
  - c. A is true but R is false.
  - d. A is false but R is true.
2. Assertion: The process of conversion of liquid water to its vapours by heating the liquid is called boiling.

Reason: The process of conversion of water vapours to liquid by cooling the vapours is called condensation.

- a. Both A and R are true and R is the correct explanation of A.
- b. Both A and R are true but R is not the correct explanation of A.
- c. A is true but R is false.
- d. A is false but R is true.

3. Assertion: Burning of wood log to charcoal is a physical change.

Reason: The products formed of burning a piece of wood can be easily converted back to wood log.

- a. Both A and R are true and R is the correct explanation of A.
- b. Both A and R are true but R is not the correct explanation of A.
- c. A is true but R is false.
- d. A is false but R is true.

4. Assertion: The formation of iron oxide from iron is a chemical change.

Reason: For the rust to form from iron, it must be exposed to air and water.

- a. Both A and R are true and R is the correct explanation of A.
- b. Both A and R are true but R is not the correct explanation of A.

- c. A is true but R is false.
- d. A is false but R is true.

5. Assertion: A drop of petrol when touched with finger gives a chill feeling.

Reason: The above phenomenon is an endothermic one.

- a. Both A and R are true and R is the correct explanation of A.
- b. Both A and R are true but R is not the correct explanation of A.
- c. A is true but R is false.
- d. A is false but R is true.

## XII. Picture based question

1. Observe the picture and list down the changes that are accompanied in the picture.

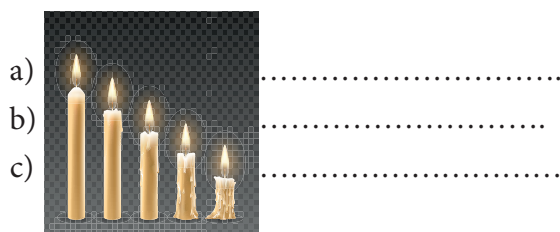

2. Observe the picture containing a kettle and note that it has salt water in it and answer the following questions:

- a) What is name of the process that is done to the kettle?
- b) What will happen to the content of the kettle?



- c) What kind of change is occurring on the cold surface of the metal plate?
- d) What can you say about the quality of water that is obtained in the beaker?





## ICT CORNER

## CHANGES AROUND US

This activity helps the students to understand the effect of heat on matters

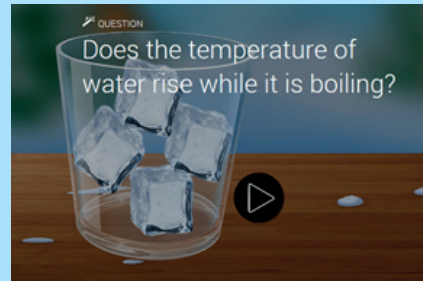

## PROCEDURE :

- Step 1:** Type the URL link given below in the browser or scan the QR code. A page opens with a glass full of ice with a play button near to it.
- Step 2:** Press Play button. It opens into another page with the set up of temperature and change of phases.
- Step 3:** Set the temperature and phases. Press the play button below.
- Step 4:** Do it with different options. Then a next page button will come
- Step 5:** Go there you will end with a small quiz.



Step 1



Step 2



Step 3



Step 4

**Changes Around Us URL:**

<https://interactives.ck12.org/simulations/chemistry/phases-of-matter/app/index.html>

\*Pictures are indicative only

\*If browser requires, allow Flash Player or Java Script to load the page.



B351\_7\_SCIENCE\_EM

# Unit 4

## Cell Biology

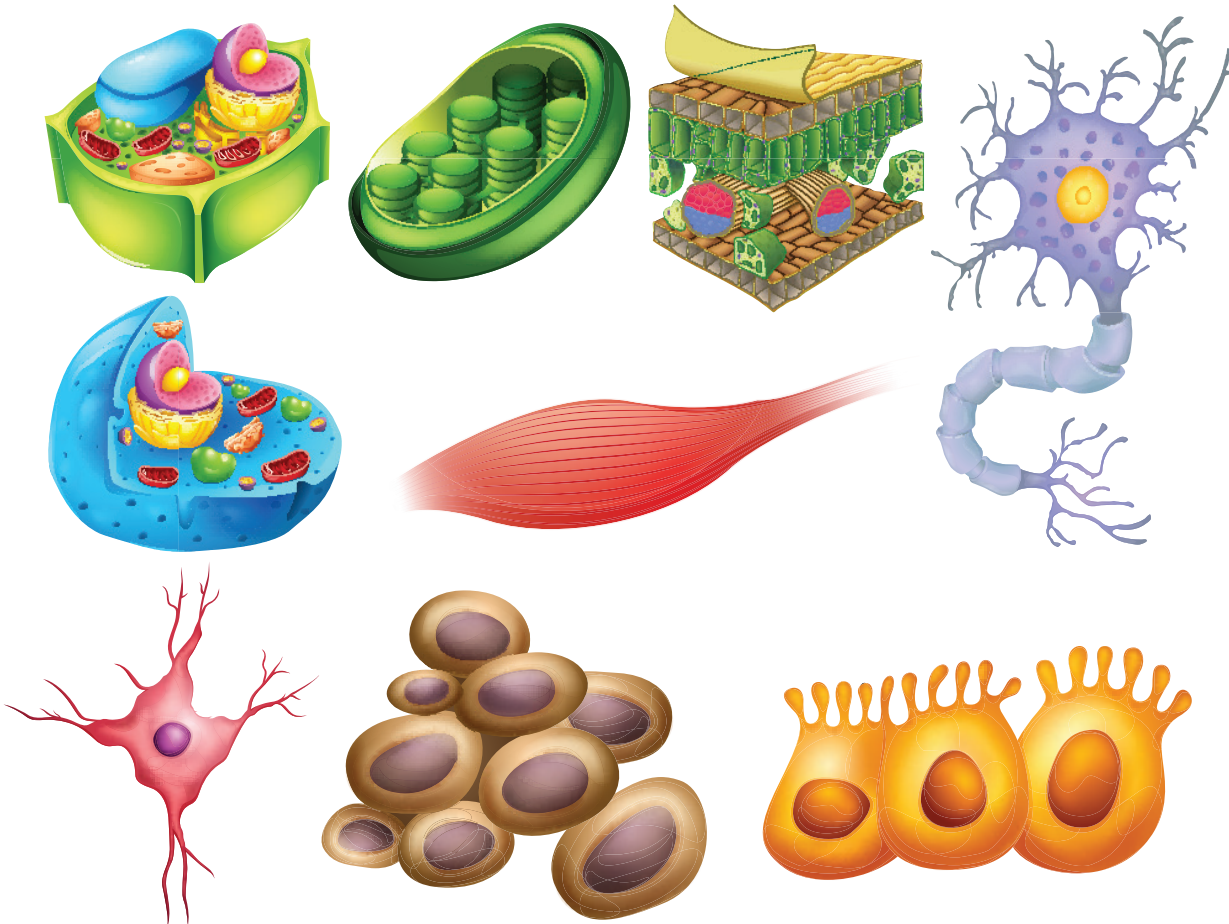

### Learning Objectives

- ❖ To compare the plant cell with the animal cell and understand their similarities and dissimilarities
- ❖ To understand the cell as a fundamental unit of life
- ❖ To know and understand the different types of Human cells and their related functions
- ❖ To know the functions of different cell organelles
- ❖ To compare different cell organelles, their functions and know their similarities and specialties



## Introduction

Sona had a dinner, some hour later, she experienced a stomach pain and went to a clinic. After examination, the Doctor told Sona that she had eaten food contaminated with a type of bacteria which might have caused food poisoning. Bacteria are micro-organisms that can be seen only under microscope and not seen through naked eyes. Salmonella species is a bacteria that can cause food-borne infection.

### Salmonella bacteria

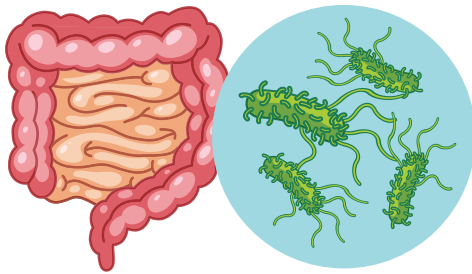

Our earth is a beautiful place where in different types of organisms happily coexist. From minute mosses to huge conifers, invisible bacteria to huge blue whale, all have a basic unit called Cell. Let us study about the cell.

## ACTIVITY 1

Do you remember the lesson studied in previous class, how will you find whether an object is living or non – living? Write it down. An object is living or non – living?

1. Form a team and work together to write down some of the functions of life, which you can remember.

2. Do you think that an individual cell is living? Explain your answer

3. Write about various organelles of a cell which you know.

### 4.1 Cell as a fundamental unit of life:

The building wall is made up of numerous bricks. In the similar manner, a bee hive is composed of numerous hexagonal units. Some of the organisms are represented by a single cell. Therefore, they show a simple organization. The basic functional unit of an organism is called, a cell. Structure of a cell represent the arrangement

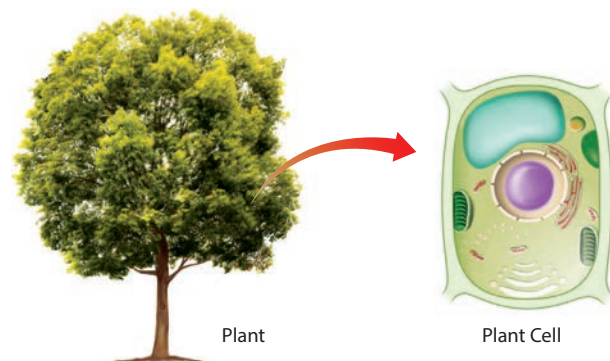
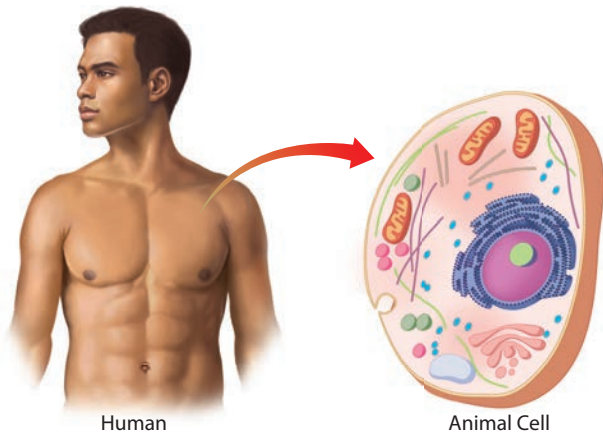
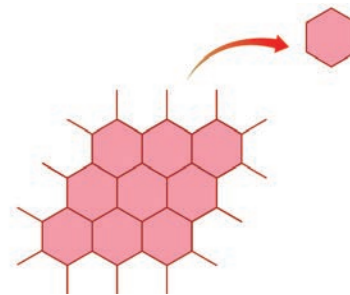
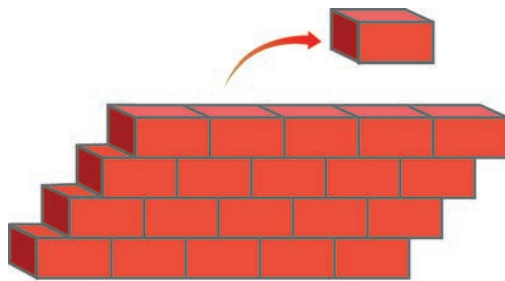

of parts or organelles in a cell. Function is the activity of each part or organelle in a cell. Cells are the basic building blocks of an organism. You learnt that atoms are the basic building blocks of matter in chapter three. Likewise, human body is made up of animal cell and plant is made up of plant cell.

### Unicellular organisms

Some simple organisms, are made up of only one cell. They are called unicellular organisms, which can be seen with the help of a microscope. There are many single-celled microscopic organisms.

Have a look at the image. *Chlamydomonas* and an *Amoeba*, a single cell organisms which carry out entire functions. The body of all organisms are made up of tiny building blocks called, cells. Bacteria are also one-celled unicellular organisms.

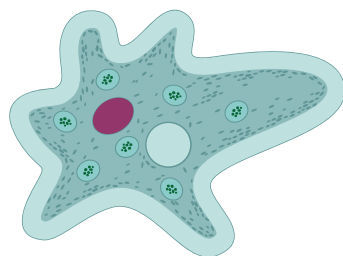

Amoeba

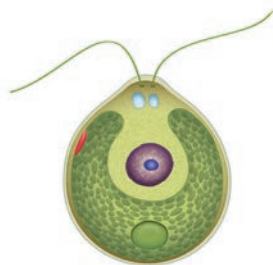

Chlamydomonas

### Multicellular Organism

The cells are organized into tissues, organs and organ systems in a multicellular organism. Macroscopic organisms are visible and consist of many cells. The body of macroscopic organisms involves various functions. You

can see cells of onion and human through a microscope. Onion and man are examples for multicellular organisms.

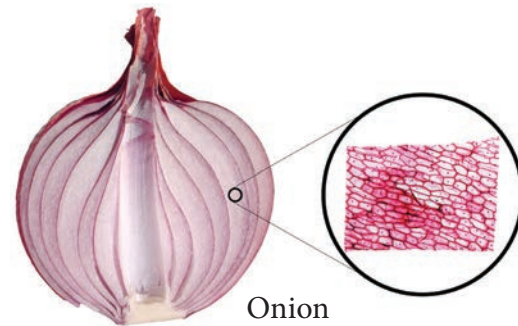

Onion



Human

### Cell to organism

Many cells function together to form tissues, different tissues combined together to form an organ and different organs to form an organ system, which leads to form an organism.

### Organisms.

Many types of organ systems function together in a body, e.g. respiratory system, digestive system, excretory system, circulatory system etc.

### Organ System

Many organs together form an organ system, which is concerned with a specific function. For example, Respiratory system, which has organs like nostrils, nasal chamber, wind pipe and lungs that help in the process of respiration. In a plant, the root system consists of primary root, secondary root and tertiary root, which does the function of conduction of



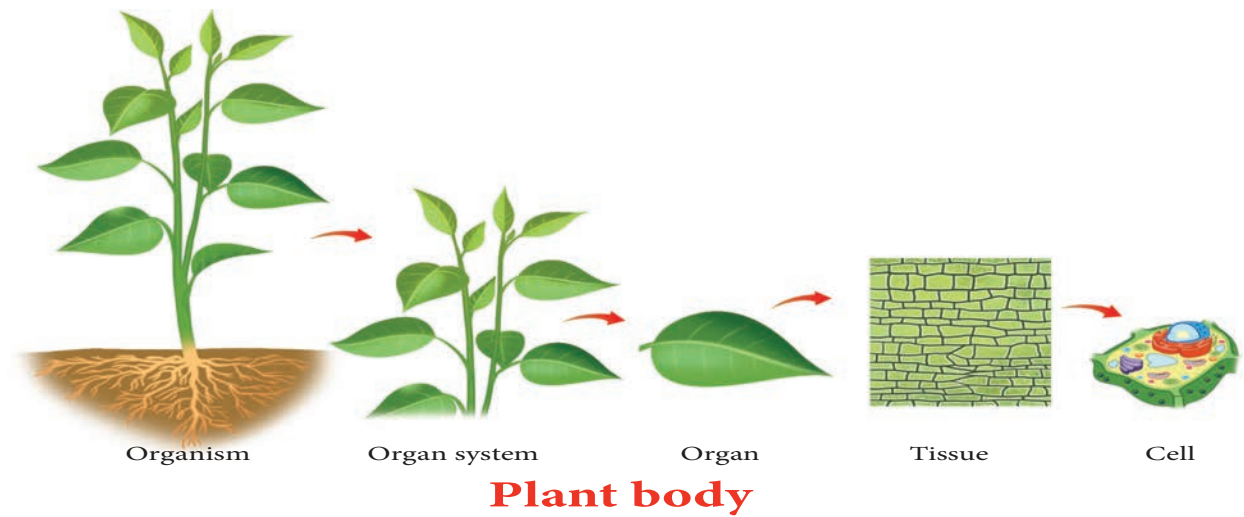
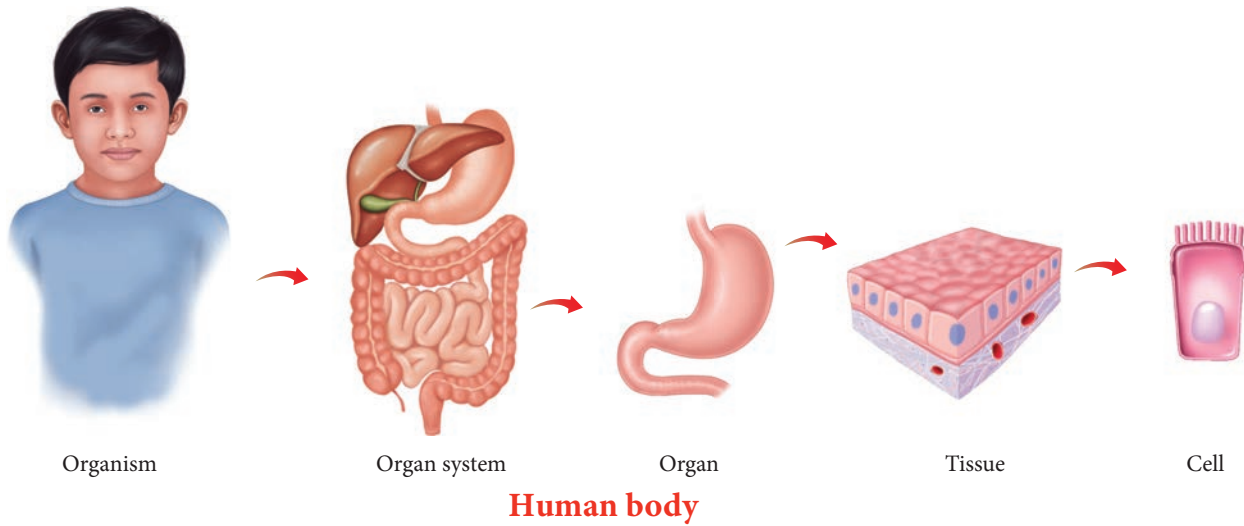

water, mineral and also fixation.

### Organ

A collection of different tissues worked together to perform a specific function or functions is called an organ. Human body has different organs like stomach, eye, heart, lungs etc., are made up of different type of tissues. Plant have organs such as leaves, stems, and roots.

### Tissue

Tissue is a group of cells, organized for a specific function. Tissues have following features like same shaped cells or different shaped cells to perform a common function. Human and other animals are made up of nervous, epithelial, connective and muscle tissues. Plants

have transport, protective and ground tissues.

### Cell

The cell is a basic structural and functional unit of life. Cell is the building unit of living organisms. You can see in a hand, how many types of cells are there to work together to perform its functions. So, cell is known as the basic unit of life.

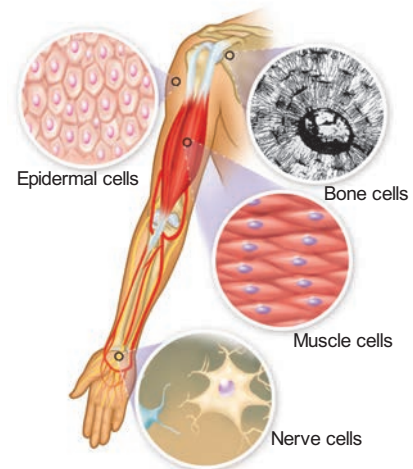



## ACTIVITY 2

Find out major organs that are part of the circulatory system of a human body and list out their functions

### 4.2 Plant and Animal cell comparison

Why do plant cells differ from animal cells? They differ from each other because they have to perform different functions.



Now you know that there are many main similarities between plant and animal cells. Let us see how they differ from one another as given in the picture (Activity 3).

### 4.3 Human cells related to functions

#### Different types of cells

Our body is made up of many different kinds of cells. Each type of cell is specialized to perform a specific function. Depending on the function, cell has specific shape, size and may have some components which other type of cells do not have. Have a look at the differences between nerve cells and red blood cells in the images. Even though there are many different types of cells, there are some components common to all type of cells. Let us take a look at this in the next section.

#### What's inside a cell?

Inside a cell, there are many tiny structures called cell organelles. These organelles are responsible for providing needs of the cell. They work to bring in food supplies, get rid of waste, protection and repair of the cell, and help it to grow and reproduce. Each one has a specific function to do for the cell. And, if any

one organelle stops its function, then the cell is programmed to die.

### Cell Structure

As we have mentioned before, all cells have some common structure.

These are

1. Cell membrane
2. Cytoplasm, and
3. Nucleus (In most eukaryotic cells).

The structure of a typical plant and animal cell shows following peculiarities:



#### Cell membrane

The boundary of an animal cell is the plasma membrane, which is also called as cell membrane

#### Cell wall - “Supporter and Protector”

All animal and plant cells are enclosed or surrounded by a cell membrane as you learned before. However, as you might have noticed previously that, animal cells often have an irregular shape, whereas plant cells have a much more regular and rigid shape.

Plant cells have an additional layer on the outer side of the cell membrane. This is called as the cell wall, that provides a frame work for support and stability.

The cell wall is formed from various compounds, the main one being cellulose. Cellulose helps to maintain the shape of the plant cell. This allows the plant to remain rigid and upright even if it grows to great heights. Each cell is interconnected with its neighboring cells through openings called Plasmodesmata.

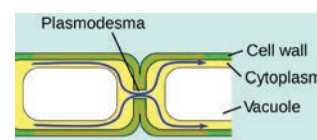

Cell wall

## PLANT CELL

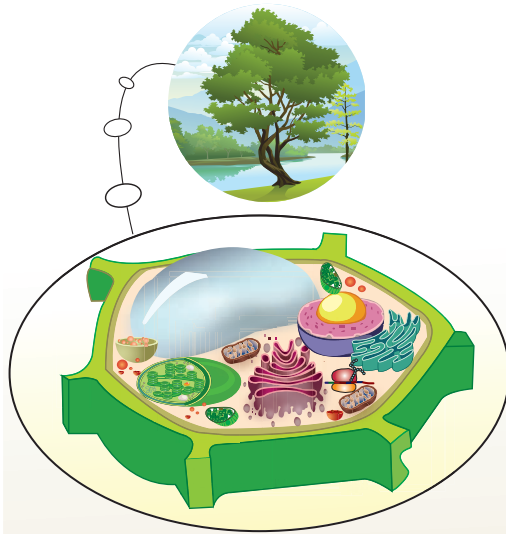

### Cell Wall



The outer most covering of the plant cell. It maintain the shape and protect the cell.

### Chloroplast



Chloroplast is a organelle, characterized by its two membranes and a high concentration of chlorophyll and carry out the photosynthesis.

### Large vacuole



filled with both inorganic and organic molecules, along with water to support the organelle

## ANIMAL CELL

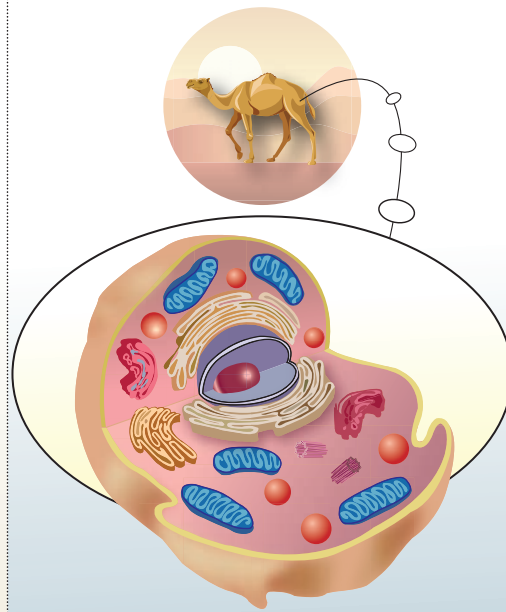

### Centriole

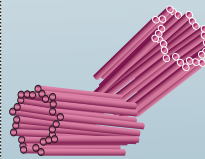

Centriole is a pair of minute cylindrical, involved in the development of spindle fibres in cell division.

### Small vacuole



filled with both inorganic and organic molecules, along with water to support the organelle

### Nucleus



The nucleus is the control centre of the cell. It is the largest Organelle.

### Ribosome

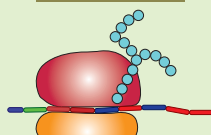

Ribosome is a minute particle consisting of RNA. They synthesize polypeptides and proteins.

### Cytoplasm

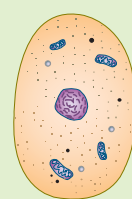

The cytoplasm includes all living parts of cell with in the cell membrane but excluding the nucleus.

### Endoplasmic reticulum

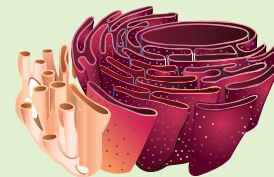

Endoplasmic reticulum a network of membranous tubules and is involved in protein and lipid synthesis.

### Golgi body

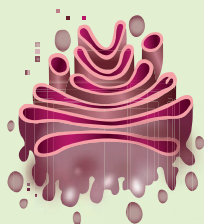

Golgi body is a complex of vesicles and folded membranes, involved in secretion and intracellular transport.

### Mitochondria

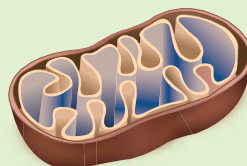

Mitochondria are organelles, They make most of the cell's supply of adenosine triphosphate (ATP), a molecule that cells use as a source of energy. Their main job is to convert energy.

### ACTIVITY 3

Study the pictures given and write the differences between cells that you observe in the given table

Plant cell	Animal Cell
<ol style="list-style-type: none"> <li>1.</li> <li>2.</li> <li>3.</li> <li>4.</li> <li>5.</li> </ol>	

Specialised cell	Structure	Function
Epithelial cells – they are mostly flat and columnar in shape		They cover the surface of the body for protection
Muscle cells – they are long and spindle shaped		They can contract and relax allowing the cell for movement.
Nerve cells – the body of nervous cell is branched with an elongated nerve fiber.		Nerve cells are specialized to carry and conduct messages that coordinate the functions of the body.
Red blood cells – Round, biconcave and disc shaped		Red blood cells carry oxygen and collect carbon dioxide from various part of the body.



## Stem Cells

Stem cells are quite amazing as they can divide and multiply while at the same time with their ability to develop into any other type of cell. Embryonic stem cells are very special as they can become absolutely any type of cell in the body, for example, blood cell, nerve cell, muscle cell or gland cell. So they are utilized by the Scientist and Medicos, to cure and prevent some diseases like Spinal cord injury.

### Human Stem Cell Applications

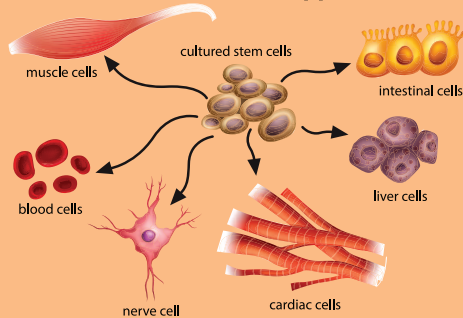

## Cytoplasm - I am the “Area of Movement”.

When you look at the temporary mounts of an onion peel, you can see a large region of each cell enclosed by the cell membrane. This region takes up very little stain. It is called the cytoplasm.

The cytoplasm includes all living parts of the cell within the cell membrane, excluding the nucleus. The cytoplasm is made up of the cytosol and cell organelles. The cytosol is a watery, jelly-like medium made up of 70% - 90% water and usually colourless.

Cell organelles and structures present in a cell are endoplasmic reticulum, vacuole, ribosome, golgi body, lysosome, mitochondria, centriole, chloroplast, surrounded by plasma membrane and cell wall.

## Protoplasm vs. Cytoplasm

In particular, the material inside and outside the nuclear membrane is known as Protoplasm. The fluid inside the nucleus is known as the nuclear fluid or nucleoplasm and outside the nucleus is called as cytoplasm.

## Inside the cytoplasm

### Mitochondria - “Power house of the Cell”.

Do you remember learning about the food as the energy source for the body? Just as wood is burnt to release the stored potential energy to make a fire to heat some water. The food that you ate to be broken down in order to release the energy which can be used by your body to function. Mitochondria are responsible to do this function.

Very active cells have more mitochondria than cells that are less active. Which type of cell, do you think, will have more mitochondria, a muscle cells or a bone cell?

Mitochondrion is an oval or rod shaped double membrane bounded organelle. Aerobic respiratory reactions take place within the mitochondrion to release energy. So it is known as “the Power House” of the cell. The energy produced within the mitochondrion is used for all the metabolic activities of the cell

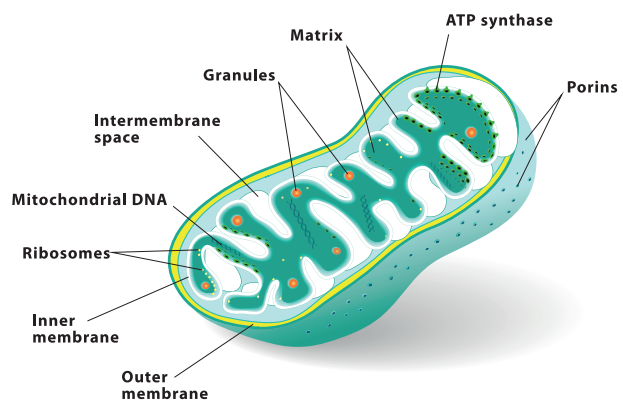

**Mitochondrion**



## Chloroplast- “Food Producers”.

Do you notice the green organelles present in plant cells and absent in animal cells. Chloroplasts are the only cell organelles that can produce food from the sun energy. Only plants with chloroplast are able to do photosynthesis because they contain the very important green pigment, chlorophyll. Chlorophyll can absorb radiant energy from the Sun and convert it to the chemical energy which can be used by the plants and animals. Animal cells lack chloroplasts and are unable to do photosynthesis.

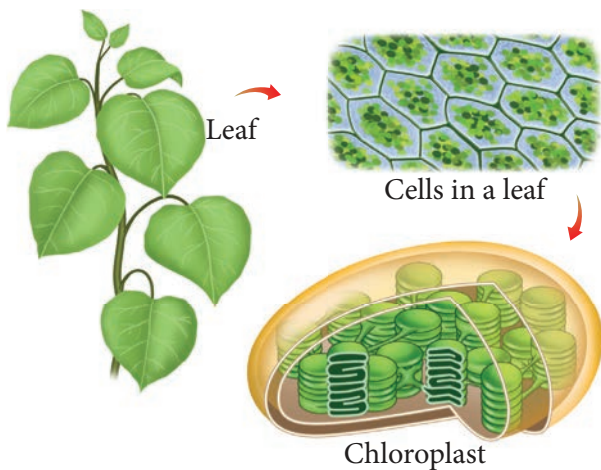

### Observing chloroplast in algae

Collect some algae from pond and separate out thin filaments of them. Place a few filaments on a slide. Observe it under the microscope. Take the help of given figure and draw the picture of chloroplast that you have observed under the microscope. Chloroplast is a type of plastid, which are present only in plant cells. Plastids are mainly of two types - chromoplasts (coloured) and leucoplasts (colourless).



Various range of these plastids impart different colours to various parts of plant. Chromoplast impart colour to flower and fruits. As fruits ripen, chloroplasts change to chromoplasts. Starch is converted to sugar.

## Golgi Complex- I need a break

Membrane bounded sacs are stacked on top of the other with associated secretory vesicles are collectively known as golgi complex. Functions of golgi complex are the production of secretory substances, packaging and secretion. This is the secret behind the change in the colour and taste of fruits

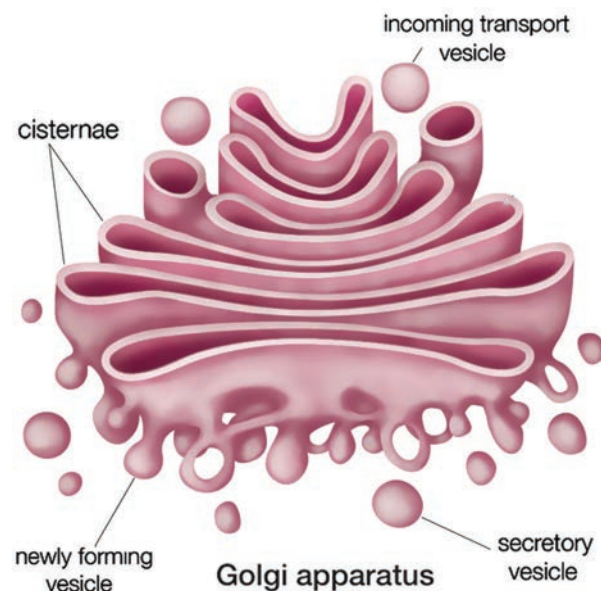

## Lysosome- “Suicidal Bag”.

### Everything I touch, I destroy

You will find organelles called as lysosomes, which are very small to view using a light microscope. They are the main digestive compartments of the cell. They lyse a cell, hence they are called “suicidal bag”.



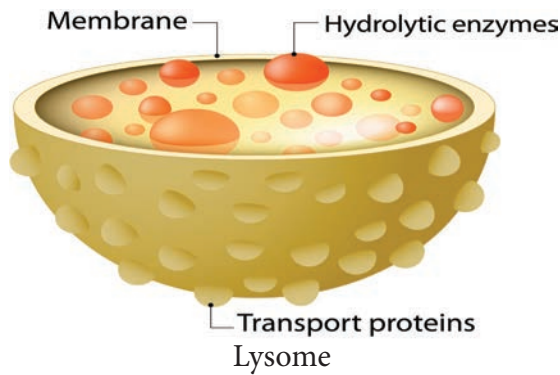

## Centrioles

They are generally found close to the nucleus and are made up of tube-like structures. Centrioles or centrosomes are present only in animal cells and absent in plant cells. It helps in the separation of chromosomes during cell division.

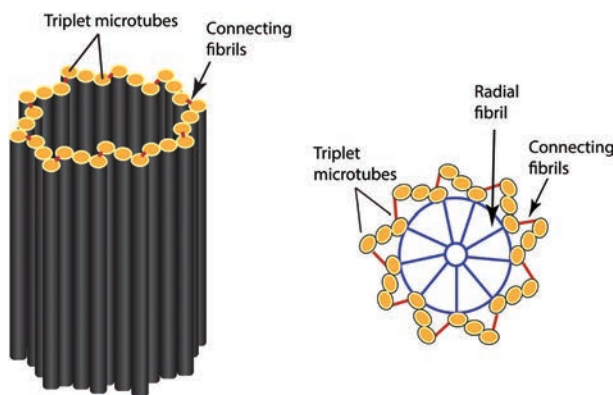

Structure of a Centriole

## Endoplasmic reticulum - You guys, be quiet, I have so much work to do

It is an inter membranous network made up of flat or tubular sacs within the cytoplasm. Endoplasmic reticulum is of two types. They are rough endoplasmic reticulum and smooth endoplasmic reticulum.

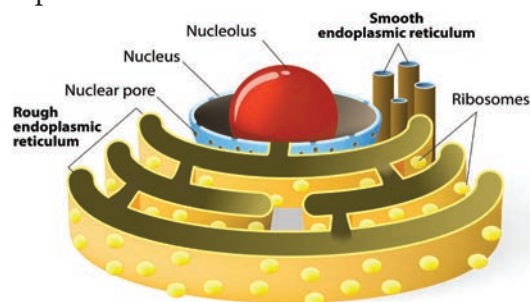

Endoplasmic reticulum

**Rough endoplasmic reticulum** are rough due to the ribosomes attached to the membrane. which helps in the synthesis of protein.

**Smooth endoplasmic reticulum.** It is a network of tubular sacs without ribosomes on the membrane. They play a role in the synthesis of lipids, steroids and also transport them within the cell.

## Nucleus - Everyone do what I say. Acting like the “Brain” of the cell

❖ Plant and animal cells have a nucleus inside the cytoplasm. It is surrounded by a nuclear envelope. One or two nucleolus and the chromatin body are present inside the nucleus. During cell division, the chromatin body is organised into a chromosome. Storage of genetic material and transfers heredity characters from generation to generation are the functions of chromosome.

### Functions of Nucleus

- ❖ In controls all the processes and chemical reactions that take place inside the cell.
- ❖ Inheritance of character from one generation to another.

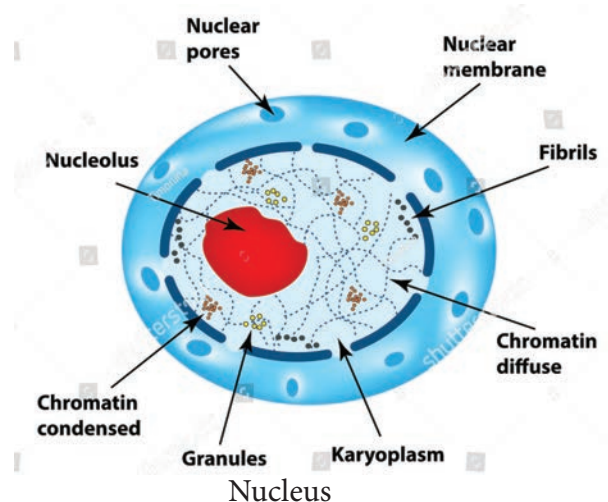

### ACTIVITY 3

#### Summarise what you have learnt

Now you've studied the internal structure of a cell. Let us summarise what we have learnt so far. Complete this table by filling the main function of each of the cell structures.

S.No	Cell Structure	Function(s)
1	Cell membrane	
2	Cell wall	
3	Cytoplasm	
4	Mitochondria	
5	Vacuole	
6	Chloroplast	
7	Endoplasmic reticulum	



#### Red blood cells

Red blood cells do not contain a nucleus. Without a nucleus, these cells die quickly; about two million red blood cells die every second! Luckily, the body produces new red blood cells every day.



#### POINTS TO REMEMBER

- ❖ Cells are the basic structural and functional units of all living organisms.
- ❖ Cells are microscopic and can be seen only under a microscope.
- ❖ Cell membranes are selectively permeable, which means they only allow certain substances to pass in and out of the cell.
- ❖ Plant cells have a cell wall around the cell membrane that is rigid and provides support and protection to the cell content.
- ❖ The Cytoplasm includes the organelles and the cytosol. The Cytosol is the jelly-like medium, in which many chemical reactions take place in the cell. Everything inside the cell membrane, except the nucleus, is considered to be the cytoplasm.
- ❖ Mitochondria are responsible for cellular respiration, which releases the energy from the food.
- ❖ Plants have chloroplasts with chlorophyll pigments to produce food by photosynthesis.
- ❖ Stem cells are cells that have the ability to divide and develop into many different types of the cell.
- ❖ A group of different tissues makes up an organ.
- ❖ Organs working together in groups form a system or organ system.
- ❖ Organ systems make up an organism, such as a human.



#### Evaluation



#### I. Choose the correct answer

1. Basis unit of life.
  - A) Cell
  - B) Protoplasm
  - C) Cellulose
  - D) Nucleus
2. I am the outer most layer of an animal cell. Who am I?
  - A) Cell wall
  - B) Nucleus
  - C) Cell membrane
  - D) Nuclear membrane

- Which part of the cell is called the brain of the cell?  
A) Lysosome      B) Ribosome  
C) Mitochondria    D) Nucleus
- \_\_\_\_\_ helps in cell division  
A) Endoplasmic reticulum  
B) Golgi complex  
C) Centriole  
D) Nucleus
- Suitable term for the various components of cell is\_\_  
A) Tissue              B) Nucleus  
C) Cell                  D) Cell organelle

### II Fill in the Blanks

- The jelly like substance present in the cell is called \_\_\_\_\_
- I convert the Sun's energy into food for the plant. Who am I? \_\_\_\_\_
- Mature Red blood cell do not contain a \_\_\_\_\_.
- Unicellular organisms can only be seen under a \_\_\_\_\_.
- Cytoplasm plus nucleoplasm is equal to\_\_\_\_\_.

### III. True or False – If false give the correct answer

- Animal cells have a cell wall.
- Salmonella is a unicellular bacteria.
- Cell membrane is fully permeable
- Only plant cells have chloroplasts.
- Human stomach is an organ.
- Ribosomes are small organelles with a membrane.

### IV. Match the following

1.	Transporting channel	Nucleus
2.	Suicidal bag	Endoplasmic reticulum
3.	Control room	Lysosome
4.	Power house	Chloroplast
5.	Food producer	Mitochondria

### V. Analogy

- Bacteria : microorganism :: mango tree : \_\_\_\_\_
- Adipose : tissue :: eye : \_\_\_\_\_
- Cell wall : plant cell :: centriole : \_\_\_\_\_
- Chloroplast : photosynthesis :: mitochondria : \_\_\_\_\_

### VI. Choose the correct alternative from the following

- Assertion (A)** : Tissue is a group of dissimilar cells.  
**Reason (R)** : Muscle is made up of Muscle cell.  
a). Both A and R are true  
b). Both A and R are false  
c). A is true but R is false.  
d). A is false but R is true.
- Assertion (A)** : Majority of cells cannot be seen directly with naked eye because.  
**Reason (R)** : Cells are microscopic.  
a). Both A and R are true  
b). Both A and R are false  
c). A is true but R is false.  
d). A is false but R is true.

### VII. Very short answer

- What are the functions of cell wall in plant cell?
- Which organelle uses energy from sunlight to make starch?

3. What are the main things in a nucleus?
4. What does cell membrane do?
5. Why lysosomes are known as scavengers of the cell?
6. Teacher said "A virus is not an organism"  
Do you agree with this statement or not?  
Explain Why?

**VIII. Give short Answer**

1. Why the cell is very important for us?
2. Distinguish between the following pairs  
Smooth ER and Rough ER  
Cell wall and cell membrane  
Chloroplast and mitochondria
3. Write correct sequence from cell to organism?
4. Write a short note on nucleus.
5. Classify the following terms into cells, tissues, organs and write in the tabular column given below  
Neuron, Lungs, Xylem, brain, adipose, Leaf, RBC, WBC, hand, muscle, heart, ovum, squamous, phloem, cartilage.

Cell	Tissue	organ

6. On the lines given below, write about what you have learned from the activities done in this lesson.

Let me tell you about some of the important things I've learned about cells. First, I'll start with...  
\_\_\_\_\_

**IX. Give long answer**

1. Write about any three organelles in detail.
2. In a situation, how to explain, while your friend ask what is this, never seen before?

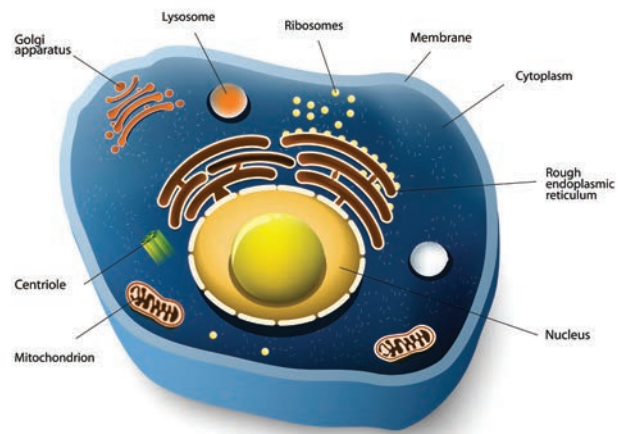

Animal Cell

3. Compare the plant cell and the animal cell and complete the illustration given below.

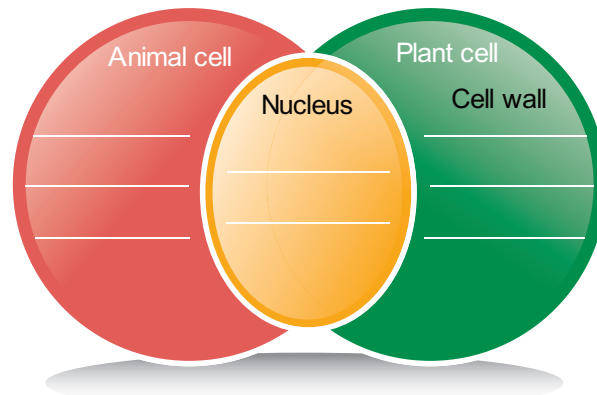

**X. Higher order thinking question**

Virus is called Acellular. Why?

# Unit 5

## Basis of Classification

### Kingdom of Organisms

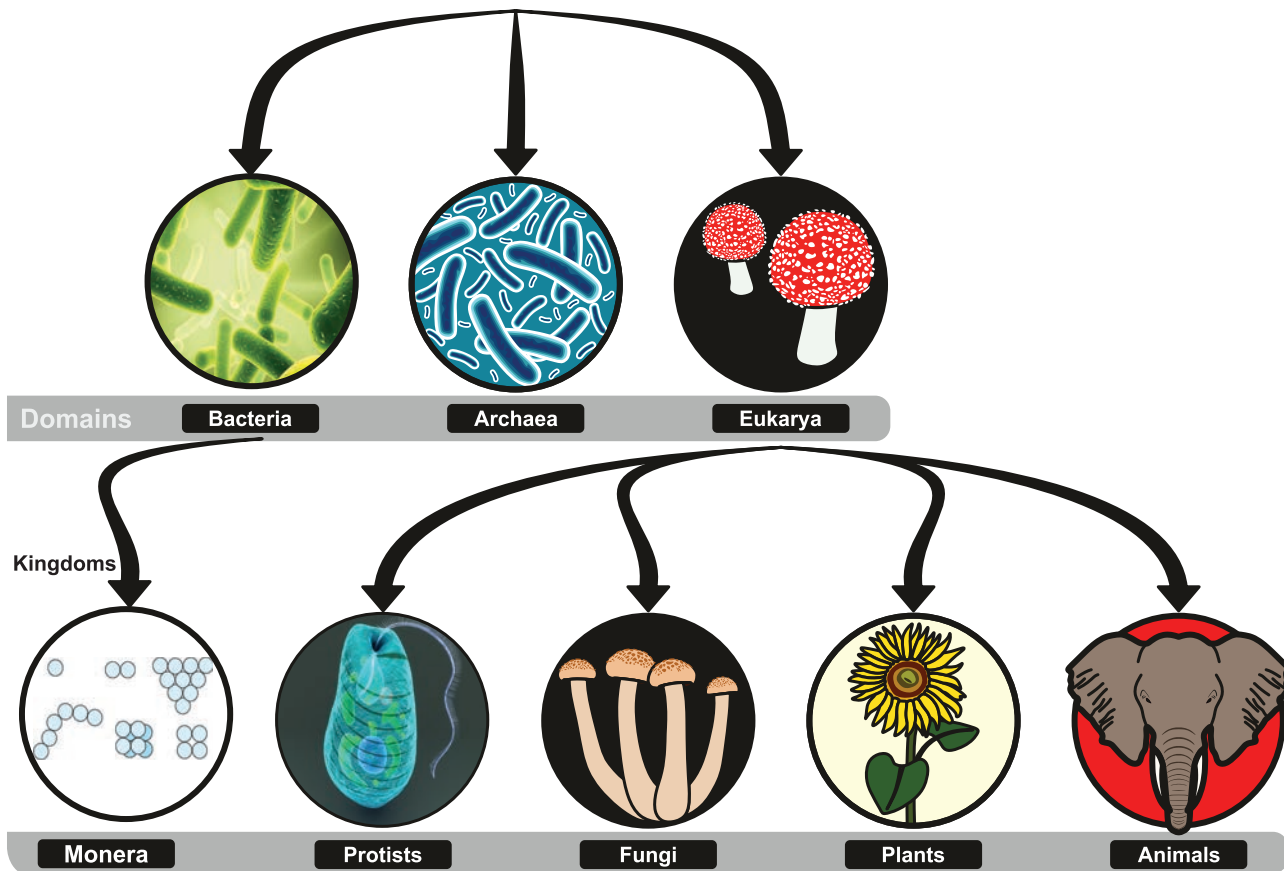

### Learning Objectives

- ❖ To understand the need for dichotomous classification
- ❖ To classify animals according to their characteristic features
- ❖ To know the classification of animals and get the knowledge about invertebrates and vertebrates
- ❖ To acquire knowledge about the classification of plants
- ❖ To know the importance of five kingdom classification
- ❖ To understand the Binomial Nomenclature





## Introduction

When you get ready to go to school, all your things - uniform, lunch box, water bottle, shoes etc., to be kept ready. Just imagine if all these things are not ready you will need to spend too much time to collect them. Likewise, in a grocery shop, medical shop and bakery all the items are systematically arranged. Sorting of things is very much required and important for all living beings. We see various plants and animals around us. It is estimated that about 8.7 million species of living organisms have been identified and named till now. However many scientists believe that, only a small portion of the total species existing on earth has been identified. In order to know about the behavior and relationship among organisms, that are known, biologists have classified them into two broad groups, plants and animals. Grouping of living organisms based on their common features is known as biological classification.

## List out things found in your class room

Chair, Table, Black board, Chalk piece, Cupboard, Fan, Light, Switches, School bag, Lunch bag, Text book, Note book, Water bottle, Pencil box, Pencil, Pen, Rubber, Ruler, Door, Window, Writing pad, Colour pencil, Eraser, Sharpener, Compass, and Chart papers.

1. Find out one common difference among these materials to classify the above things into two **Wooden / Non Wooden**
2. Find out another difference to classify each group into two sub groups Wooden sitting materials / Wooden writing materials and Non wooden sitting material / Non wooden writing materials.
3. Continue to identify differences to classify each small subgroups into two Fixed / Portable, With arm / Without arm

There are some similarities and differences exist among these materials. So we need to observe and identify those similarities and differences to

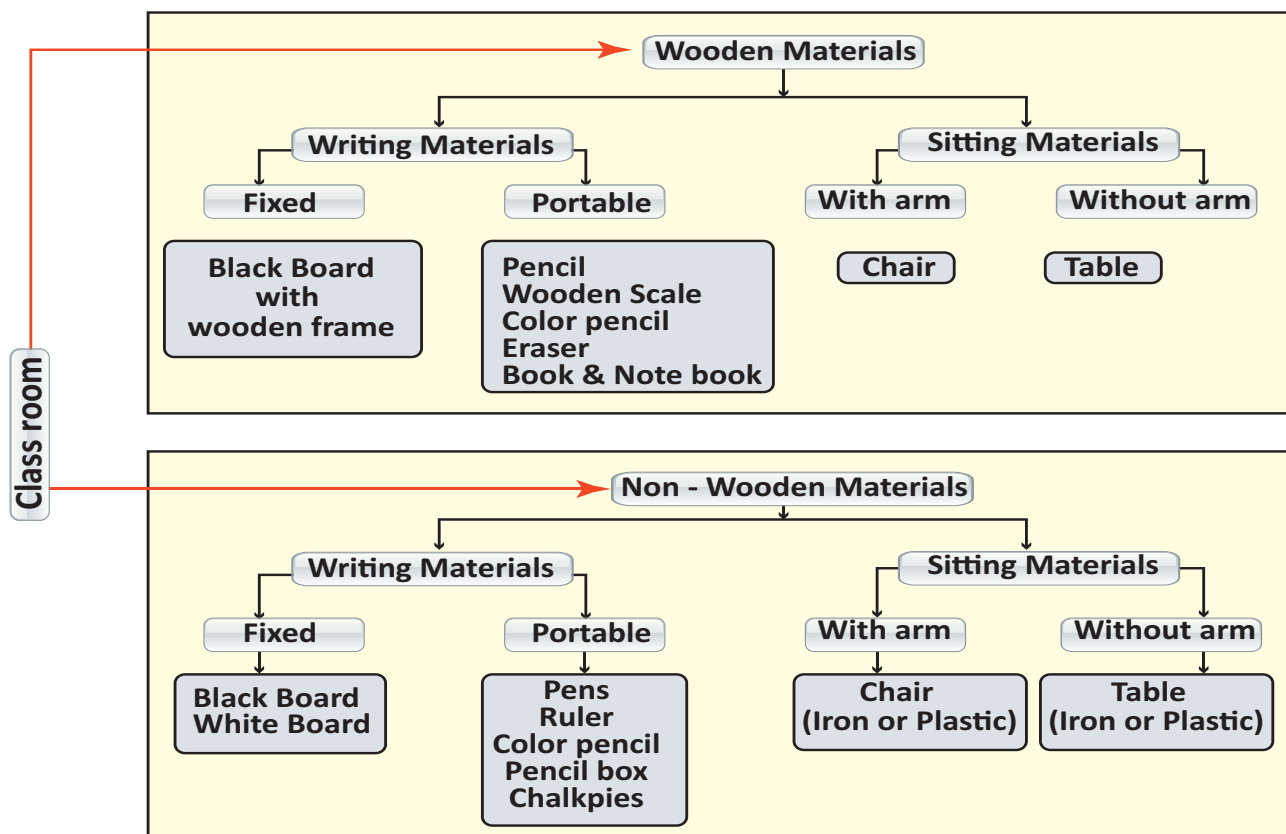

construct a dichotomous key. The dichotomous key allows us to make quick reference and identify a particular thing. Classification provides scientists a systematic easy way of studying organisms. Classification is done using this dichotomous key. What is dichotomous key? It is a tool used to classify organisms based on their similarities and differences.

### Features of dichotomous key

- A single feature that differentiate a group easily.
- One character selected to separate the group, as present or absent.
- Continue the 2nd step until only one item will remain at the end.

### Dichotomy of Animals

Using a dichotomy pattern, classify the given

list of animals: Ostrich, peacock, monkey, frog, toad, turtle, snake, shark, goldfish, ant, tapeworm, earthworm and leech.

1. Presence or absence of back bone, we can classify them into two groups.
2. Animals with back bone can be divided into its subgroup based on its body temperature.
3. Further classification can be done based on its difference like presence of feather or hair, scales etc.

### 5.1. Basics of Classification:

Living organisms are so large in number that they need to be classified into smaller groups. Classification of living organisms is made on the basis of their characteristics, similarities and differences

**Identify animals with backbone and without backbone based on the figure.**

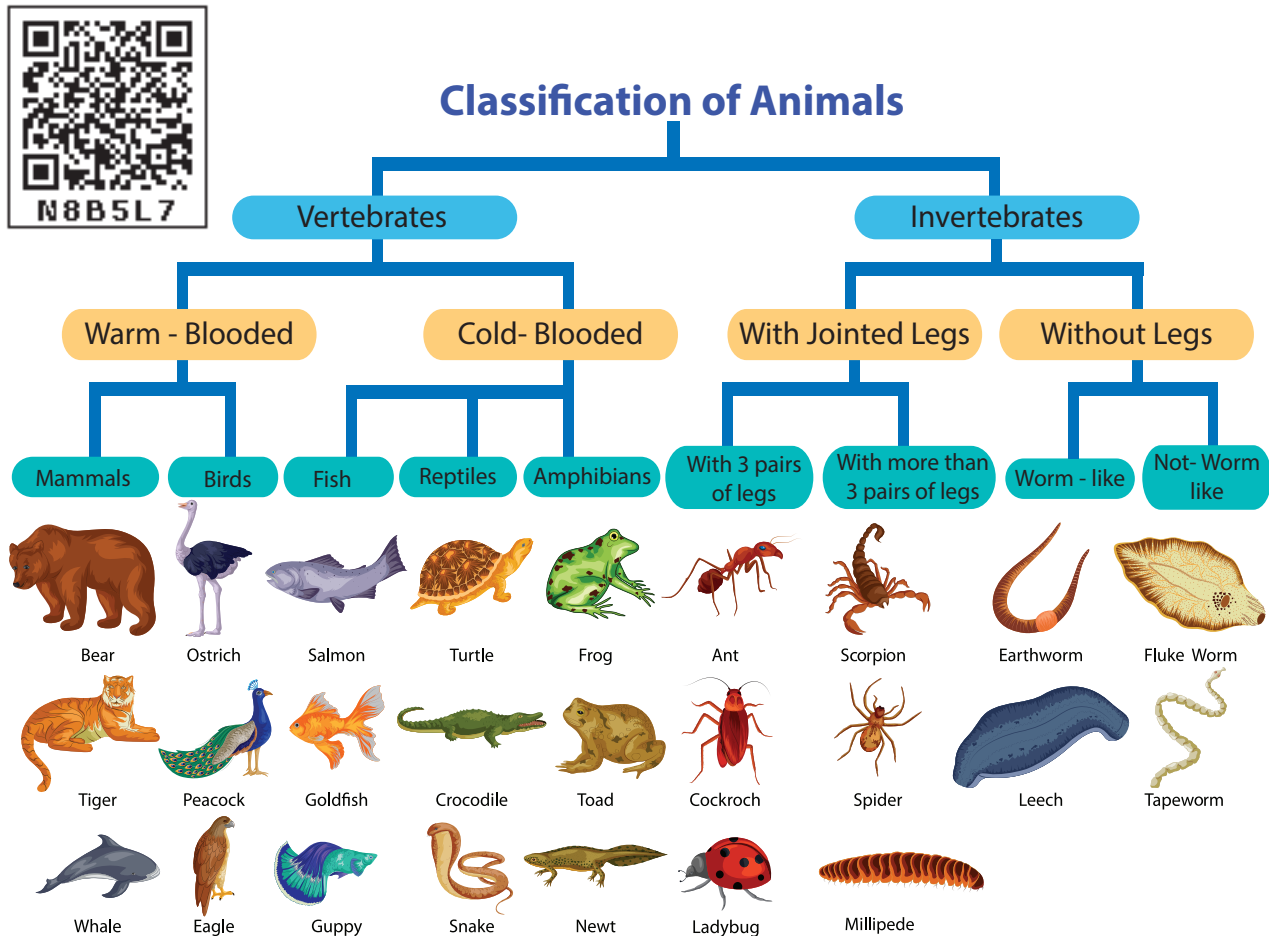



**Aristotle** was a Greek philosopher and thinker who lived about 2400 years ago. Aristotle came up with the following grouping system that was used for almost 2000 years after his death!

- He classified all organisms into either animals or plants.
- Then he classified into those 'with blood' and those 'without blood'.
- Then the animals are classified into three groups based on their method of movement: walkers, flyers or swimmers.



### ACTIVITY 1

**Aim :** To sort out a box of given buttons and classify them into different types.

**Materials Required :** A box full of different types of buttons.

**Procedure:**

1. Take a box of given buttons.
2. Work in small groups of three or four and classify the buttons based on the following classification criteria.
  - (i) Shape
  - (ii) Buttons with four holes
  - (iii) Buttons with two holes.
  - (iv) Colour
3. Identify other features that can be used to sort out buttons into different groups.



Based on the, special features and characters, the students identify each button, according to its size, hole and colour. This is known as identification. Then teacher shall ask students to separate the buttons according to the size, hole and colours. This is known as assortment.

After assorting the buttons the teacher ask the students to gather the buttons according to their, size, hole and colours. This is termed as grouping. Identification, assortment and grouping, which results in classification

### Classification:

The method of arranging the organisms into groups is called classification. When we classify things we put them into groups based on their characteristics.

### Why do we classify things?

1. Classifying things makes it easy for us to know their similarities and differences.
2. Things with similar characters are classified into same group. These things are usually similar in at least one characteristic.
3. Things with different characteristics are classified into different groups. These things are usually different in at least one characteristic.
4. Classification helps us to understand, living and non – living things in better way. For example, we can classify a newly discovered organism, we would come to know, how it relates with other.

### Need for Classification

- ❖ Classification is needed to identify an organism correctly.
- ❖ It helps to know the origin and evolution of an organism.
- ❖ To establish the relationship among different organisms.









- ❖ It provides the information about living things in different geographical regions.
- ❖ It helps in understanding how complex organisms must have evolved from simpler ones.

Scientists have been able to discover and classify more than 2 million organisms on the earth ranging from tiny bacteria to the largest blue whales. Each organism has been classified in a category based on its evolutionary relationship with other group of organisms. We can define hierarchy of organisms as:

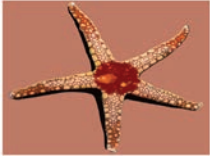
“The system of arranging taxonomic categories in a descending order based on their relationships with other group of organism is called **hierarchy of categories**”. This system was introduced by Linnaeus and is called **Linnaean hierarchy**. There are seven main categories of hierarchies namely, **Kingdom, Phylum, Class, Order, Family, Genus and Species**. Species is the basic unit of classification

**Based on the above classification the following table shows different phylum, with general features and examples of different phyla and classes**

S. NO	General Characters	Division
1	Microscopic unicellular, pseudopodia, flagella and cilia for locomotion, reproduce by fission or conjugation.	Phylum <b>Protozoa</b> Eg. <i>Amoeba</i> , <i>Euglena</i> and <i>Paramecium</i>
2	Multicellular organisms with holes in the body. Skeleton formed of spicules, asexual and sexual reproduction.	<b>Phylum Porifera</b> Eg. <i>Leucosolenia</i> , <i>Spongilla</i> , <i>Sycon</i> .
3	Multicellular organisms Diploblastic, sessile or free swimming, solitary or colonial, asexual and sexual reproduction	Phylum <b>Coelenterata</b> Eg. Hydra, Sea anemone, Jelly fish, Corals.
4	Acoelomates, parasites inside the body of animals and human beings, mostly hermaphrodite (bisexual).	Phylum <b>Platyhelminthes</b> Eg. <i>Planaria</i> , Liver fluke, Blood fluke, Tapeworm
5	Unsegmented body, mostly parasites in human beings and animals, causing diseases, asexual reproduction.	Phylum <b>Aschelminthes</b> or Nematoda Eg. <i>Ascaris lumbricoides</i>
6	Triploblastic, segmented body, mostly hermaphrodite (bisexual and unisexual).	<b>Phylum Annelida</b> Eg. Earthworm, Nereis, Leech.

7	Segmented body, thick chitinous cuticle forming an exoskeleton, paired and jointed legs, unisexual exhibits sexual dimorphism.	Phylum <b>Arthropoda</b> Eg. Crab, Prawn, Millipede, Insects, Scorpion, Spider	
8	Soft bodied, unsegmented, muscular head, foot and visceral mass, mantle, a calcareous shell, sexual reproduction.	Phylum <b>Mollusca</b> Eg. Cuttle fish, Snail, Octopus	
9	Exclusively marine, spines and spicules over the body, water vascular system, tube feet, for feeding, respiration and locomotion, sexual reproduction.	Phylum <b>Echinodermata</b> Eg. Starfish, Sea – Urchin, Brittle star, Sea cucumber and Sea- lily	
<b>Phylum - CHORDATES</b>			
10	Aquatic, cold blooded vertebrates with boat shape body and jaws, locomotion by paired and median fins, sexual reproduction.	Class <b>Pisces</b> Shark, Catla, Mullet, Tilapia	
11	Amphibious, cold- blooded, two pairs of limbs, sexual reproduction.	Class <b>Amphibia</b> Eg. Frog, Toad, Salamander, Caecilian	
12	Cold- blooded , lung breathing, scales over the body, pentadactyl limb, adapted for climbing, running and padding, oviparous.	Class <b>Reptilia</b> Garden lizard, House lizard, Turtles, Tortoise , Snakes, Crocodile	
13	Warm blooded, exoskeleton of feathers, flight adaptation, spongy bones with air cavities, powerful eyes, sexual reproduction, oviparous.	Class <b>Aves</b> Wader bird, Roller bird, Hoopoe bird, Parrot, Sparrow, Hen, Ostrich, Kiwi	
14	Terrestrial warm blooded, external ear or pinna, muscular diaphragm, non – nucleated RBC, heterodont and diphodont dentition, viviparous give birth to young ones.	Class <b>Mammalia</b> Duck bill Platypus, Kangaroo, Cat, Dog, Tiger, Zebra, Man	



## ACTIVITY 2

Fill up the blanks with the suitable organisms

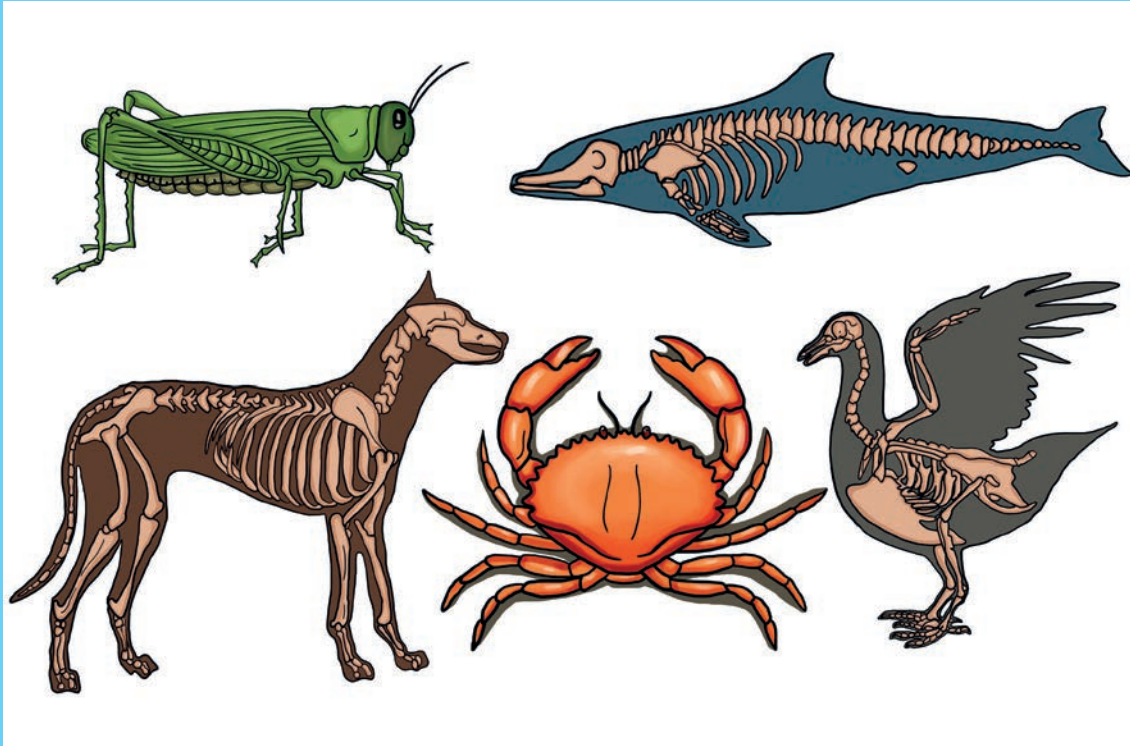

1. Vertebrates \_\_\_\_\_, \_\_\_\_\_ and \_\_\_\_\_
2. Invertebrates \_\_\_\_\_, \_\_\_\_\_ and \_\_\_\_\_.
3. Name the vertebrates with wings \_\_\_\_\_, \_\_\_\_\_.
4. Name the invertebrates with wings \_\_\_\_\_, \_\_\_\_\_.
5. Name the invertebrates with segmented legs \_\_\_\_\_, \_\_\_\_\_.
6. Name the invertebrates with Jointed legs \_\_\_\_\_, \_\_\_\_\_.
7. Name the warm blooded vertebrates \_\_\_\_\_
8. Name the cold blooded vertebrates \_\_\_\_\_.
9. Name the vertebrates with lungs respiration \_\_\_\_\_, \_\_\_\_\_.
10. Name the animal with beak \_\_\_\_\_.

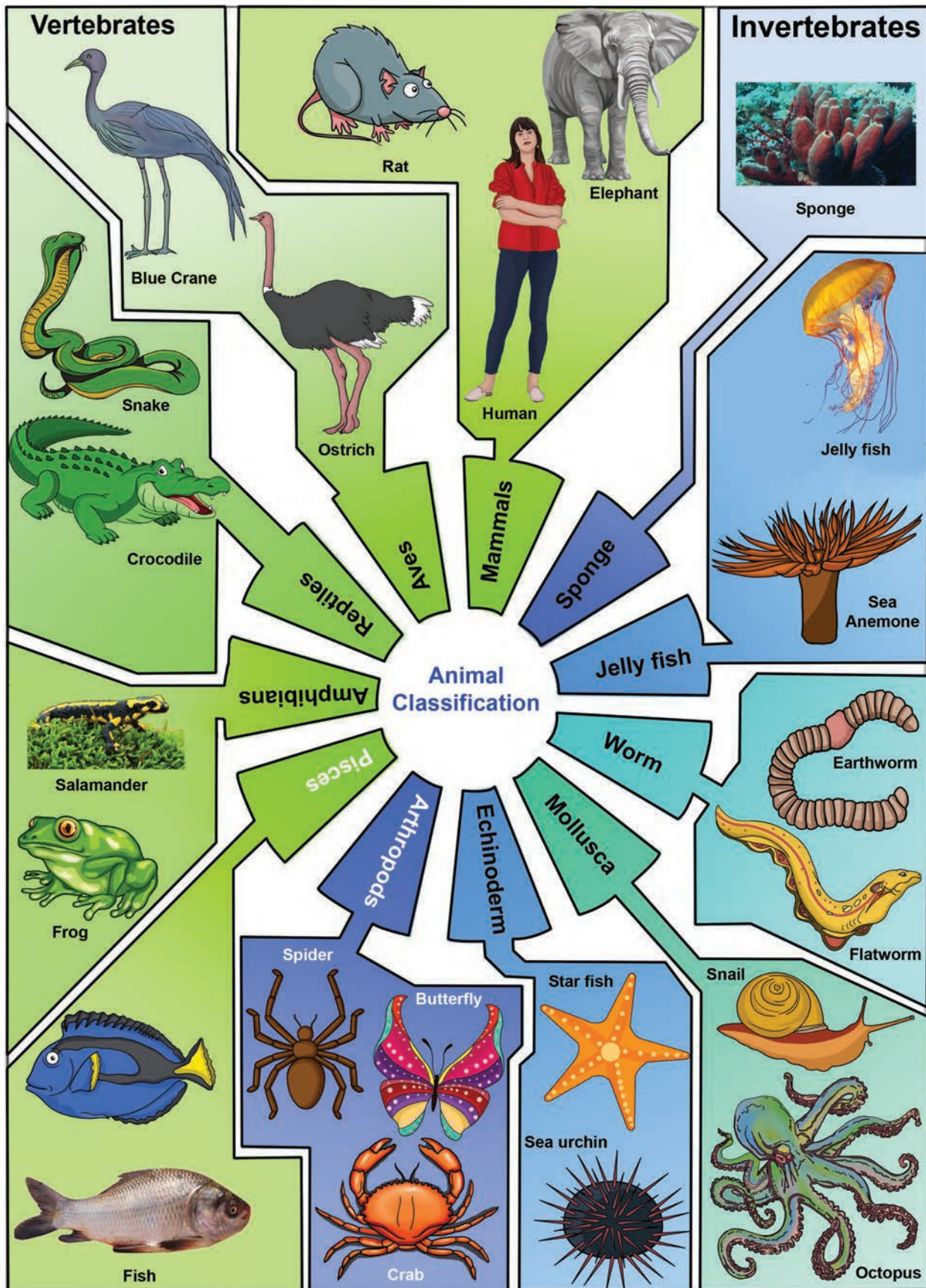

### ACTIVITY 3

Given table shows the name of the phylum and its characteristic features. Write name of the animals belonging to the respective phylum.

Phylum	Characters	Example
Porifera	Pore bearers	
Coelenterata	Gastro vascular cavity	
Platyhelminthes	Flame cells	
Aschelminthes	Thread like worms	
Annelida	Body is segmented	
Arthropoda	Have jointed legs	
Mollusca	Soft bodied with shells	
Echinodermata	Spines on the skin	
Chordata	Have back bone	

### 5.2. Classification of Plants

Based on dichotomy, plants also can be classified into two main groups – Flowering and Non – flowering. Non – flowering plants do not produce seeds and flowering plants produce seeds. Based on their nature of plant body, Non – flowering plants are classified into three types: algae, mosses and ferns. Based on their fruit

body, flowering plants are classified into two types: gymnosperms and angiosperms.

#### Algae

- ❖ Plant is thallus, not well-differentiated into root, stem, and leaves.
- ❖ They are predominantly aquatic.
- ❖ They are unicellular or multicellular - filamentous. Example - Chara

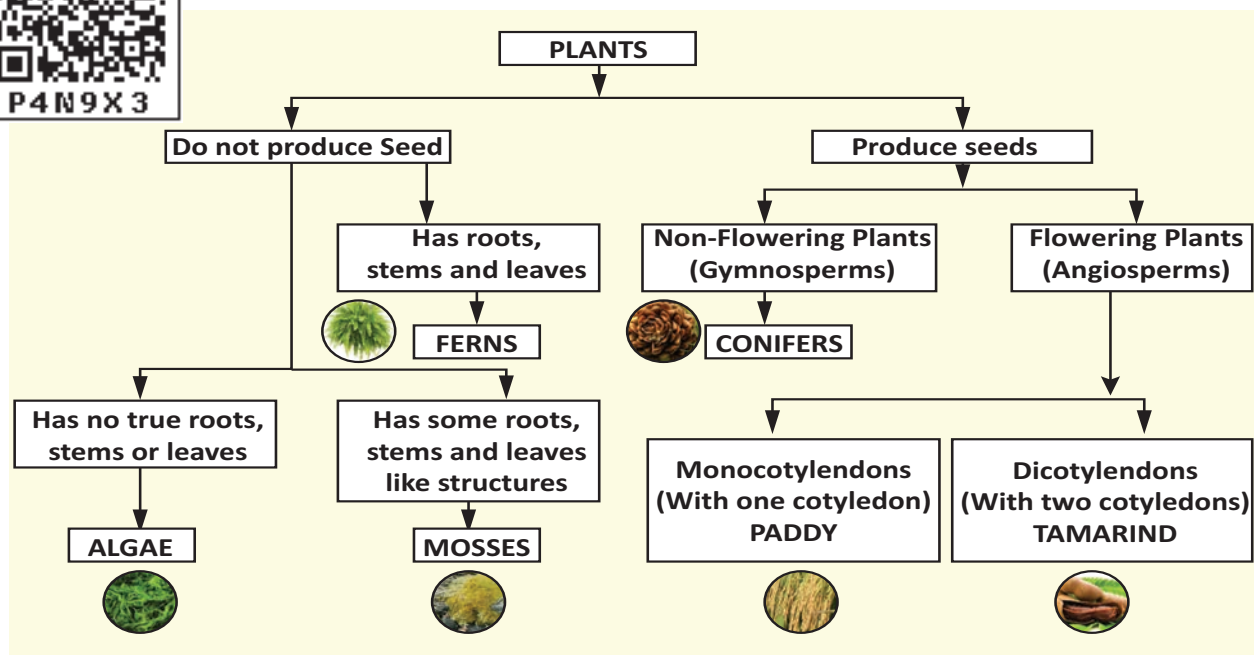



*Chara*

### Mosses

- ❖ Plant body is not differentiated into true root, stem and leaves.
- ❖ They are water living plants, needs moisture to complete its life cycle. Hence they are referred to as amphibious plants.
- ❖ They do not have any specialized vascular tissues for conduction of water and food. Examples: *Funaria*

### Ferns

- ❖ Plant body is well-differentiated into root, stem, and leaves. Leaves may be large or small.
- ❖ Specialized vascular tissues are found for the conduction of water and food.
- ❖ Basically they are the first land plants which grows well in shady, moist, and cool places. (Examples: *Adiantum*)

*Adiantum*

### Gymnosperms

- ❖ Plants are perennial, woody, evergreen with true root, stem and leaves.
- ❖ They possess vascular tissues, xylem without vessels and phloem without companion cells.
- ❖ Ovules are naked, without ovary. Hence they do not produce fruits. Seed are naked. (Examples: *Pinus*, *Cycas*)

*Pinus*

### Angiosperms

- ❖ Plant body is well differentiated into true root, stem, and leaves.
- ❖ They produce flower with four whorls (calyx, corolla, androecium and gynoecium), hence known as flowering plants.
- ❖ Female reproductive organ, ovary is present inside the flower which develops into fruit and ovule develops into seed.
- ❖ Plant possess well developed vascular system with xylem vessels and phloem – companion cells.

Angiosperms are the dominant plant forms of present day. Based on the number of cotyledons, angiosperms are broadly divided into two groups. a) **monocotyledons** b) **dicotyledons**. Plant seeds which have only one

cotyledon are said to be monocots. Plant seeds which have two cotyledons are known as dicots. Example- Paddy (monocot), tamarind (dicot).

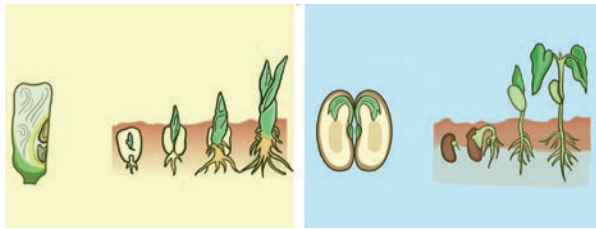

Paddy

Tamarind



Monocotyledon



Dicotyledon

### 5.3 The Five Kingdom Classification

The five kingdom classification was proposed by **R.H. Whittaker** in 1969. Five kingdoms were formed on the basis of characteristics such as cell structure, mode of nutrition, source of nutrition and body organization.

#### Monera

#### Kingdom Monera - Bacteria

All prokaryotes belong to the Kingdom Monera, which do not possess true nucleus. Cells of prokaryotes do not have a nuclear membrane and any membrane bound organelles. Most of

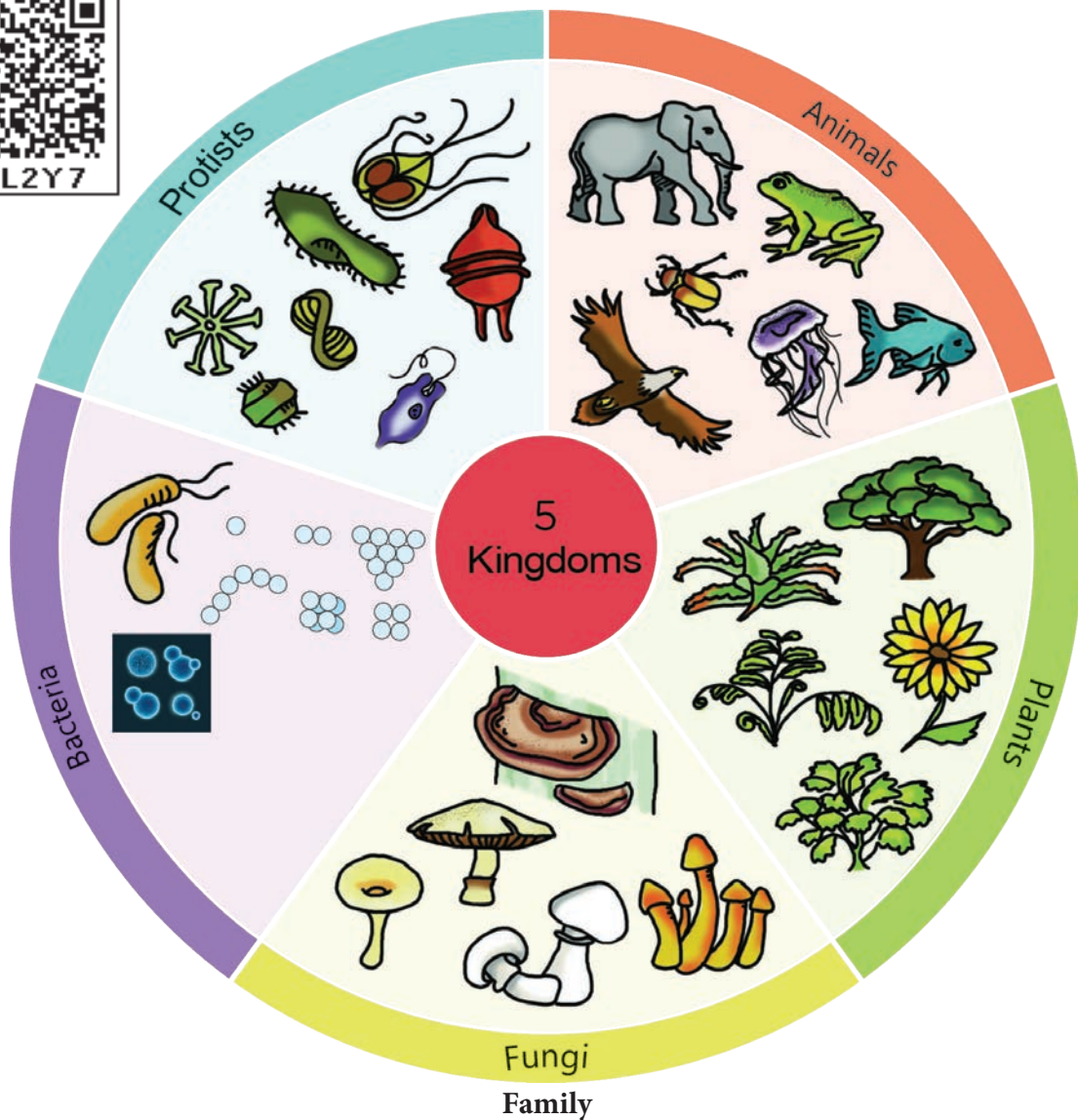



the bacteria are heterotrophic, but some are autotrophs. Bacteria and Blue green algae are examples for monera.



Bacteria  
**Kingdom Protista:**

Blue green alge

The Kingdom Protista includes unicellular and a few simple multicellular eukaryotes.

There are two main groups of protists. The plant like protists are photosynthetic and are commonly called algae. Algae include unicellular and multicellular types. Animals like protists are often called **protozoans**. They include *amoeba* and *paramecium*.

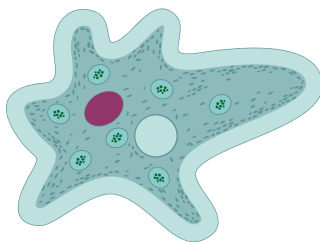

*Amoeba*

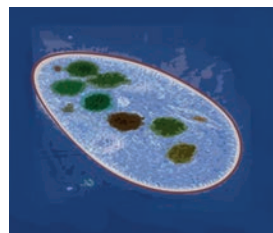

*Paramecium*

### Kingdom Fungi:

Fungi are eukaryotic, and mostly are multicellular. They secrete enzymes to digest the food and absorb the food after digested by the enzymes. Fungi saprophytes as decomposers (decay –causing organisms) or as parasites. Kingdom Fungi includes molds, mildews, mushrooms and yeast.



Mushroom

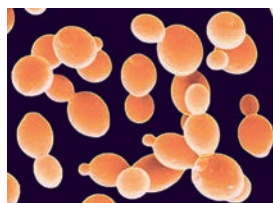

Yeast

### Kingdom Plantae:

Plantae (plants) are multicellular eukaryotes that carry out photosynthesis. Reserve food materials are starch and lipids in the form of oil or fat. Plant cells have cell wall and specialized functions, such as photosynthesis, transport of materials and support. Kingdom Plantae includes ferns, cone bearing plants and flowering plants.



Ferns

Cone bearing plants



Flowering plants

### Kingdom Animalia:

Animalia (animals) are multicellular, eukaryotic and heterotrophic animals. Cells have no cell wall. Most members of the animal kingdom can move from place to place. Eg. Invertebrates like sponges, hydra, flatworms round worms, insects, snails, starfishes. Vertebrates like Fish, amphibians, reptiles, birds, and mammals including human beings belong to the kingdom Animalia.



Fish (Pisces)



Frog (Amphibian)



Crocodile (Reptiles)



Cow (Mammals)



Bird (Aves)

### IMPORTANT CHARACTERISTICS OF FIVE KINGDOMS

Characteristics	Monera	Protista	Fungi	Plantae	Animalia
1. Cell Type	Unicellular, Prokaryotic.	Unicellular, Eukaryotic.	Multicellular, Non – green and Eukaryotic.	Multicellular, Eukaryotic.	Multicellular, Eukaryotic.
2. Nucleus	Absent.	Present.	Present.	Present.	Present.
3. Body Organisation	Cellular level of organization	Cellular level of organization is	Multi cellular with loose tissue.	Tissue level and organ level.	Tissue, organ and organ system.
4. Mode of Nutrition	Auto (or) Heterotrophic.	Auto (or) Heterotrophic.	Saprophytic, parasitic some-time symbiotic	Autotrophic.	Heterotrophic.
5. Example	Bacteria and Blue green algae.	Spirogyra and Chlamydomonas.	Rhizopus and Agaricus.	Herb, Shrub and Trees.	Fish, frog, crocodile, Birds and human being

#### Merits of five Kingdom Classification

- ❖ This system of classification is more scientific and natural.
- ❖ This system of classification clearly indicates the cellular organization, mode of nutrition, and characters for early evolution of life.
- ❖ It is the most accepted system of modern classification as the different groups of organisms are placed phylogenetically.

- ❖ It indicates gradual evolution of complex organisms from simpler one.

#### Demerits of five Kingdom Classifications

- ❖ In this system of classification of viruses have not been given a proper place.
- ❖ Multicellular organisms have originated several times from protists.

- ❖ This type of classification has drawn back with reference to the lower forms of life.
- ❖ Some organisms included under protista are not eukaryotic.

#### 5.4. Binomial Nomenclature

**Gaspard Bauhin** in 1623, introduced naming of organisms with two names which is known as Binomial nomenclature, and it was implemented by **Carolus Linnaeus** in 1753. He is known as ‘**Father of Modern Taxonomy**’.



**Binomial nomenclature** is an universal system of naming organisms. As per this system, each organism has two names – the first is the **Genus** name and the second is the **Species** name. Genus name begins with a capital letter and Species name begins with a small letter.

**Example:** The nomenclature for onion is *Allium sativum*. Genus name is *Allium*, species name is *sativum*.

Vernacular name is a local name that is familiar for a particular place. Binomial name is an universal name which never changes. Binomial nomenclature and classification helps scientists to identify any organisms and to place them at a particular hierarchy.

#### ACTIVITY 4

Field trip to sanctuaries / zoo should be arranged. Students are guided to observe the animals and explain about the feature of animals how they are protected and maintained in the zoo. Note the displayed names of the plants and animals. Discuss your observation in the class

#### Scientific Names of Some Organisms



S.No	Common Name	Scientific Name
1.	Human being	<i>Homo sapiens</i>
2.	Onion	<i>Allium sativum</i>
3.	Rat	<i>Rattus rattus</i>
4.	Pigeon	<i>Columba livia</i>
5.	Tamarind	<i>Tamirindus indica</i>
6.	Lime	<i>Citrus aurantifolia</i>
7.	Neem Tree	<i>Azadirachta indica</i>
8.	Frog	<i>Rana hexadactyla</i>
9.	Coconut	<i>Cocos nucifera</i>
10.	Paddy	<i>Oryza sativa</i>
11.	Fish	<i>Catla catla</i>
12.	Orange	<i>Citrus sinensis</i>
13.	Ginger	<i>Zingiber officinale</i>
14.	Papaya	<i>Carica papaya</i>
15.	Date	<i>Phoenix dactylifera</i>

#### POINTS TO REMEMBER

- ❖ Classification of living organisms is made on the basis of their characteristics, similarities and differences.
- ❖ Classification is needful to identify living organisms and to study about them conveniently
- ❖ Kingdom is the largest division of the living world and species is the basic unit of classification.
- ❖ Kingdom Animalia is divided into 2 sub kingdoms.
  - Invertebrates (Animals without back bone)
  - Vertebrates (Animals with back bone)
- ❖ Invertebrates are classified into nine phyla
- ❖ Vertebrates are classified into five classes

- ❖ Plants are classified into flowering and non – flowering plants and further classified into groups based on their nature of plant body and fruiting body.
- ❖ In 1969, R.H. Whittakar proposed a five kingdom classification of living organisms.
- ❖ The Five kingdom classification includes five kingdom namely – Monera, Protista, Fungi, Plantae and Animalia.
- ❖ Gaspard Bauhin is 1623, introduced the binomial nomenclature and it was implemented by Carolus Linnaeus in 1753.
- ❖ Binomial nomenclature is an universal system of naming organisms. It contain two names
- ❖ The first name of binomial is genus name and the second name is species name
- ❖ Carolus Linnaeus is known as Father of Modern Taxonomy



### Evaluation

#### I. Choose the correct answer.

1. The following characteristics are essential for classification.
  - (a) Similarities            (b) Differences
  - (c) Both of them          (d) None of them
2. Approximately \_\_\_\_\_ species of living organisms found in the earth.
  - (a) 8.7 million            (b) 8.6 million
  - (c) 8.5 million            (d) 8.8 million
3. The largest division of the living world is \_\_\_\_\_
  - (a) Order                    (b) Kingdom
  - (c) Phylum                (d) Family



4. Who proposed the five kingdom of classification?
  - (a) Aristotle                (b) Linnaeus
  - (c) Whittakar               (d) Plato
5. The binomial name of pigeon is \_\_\_\_\_
  - (a) *Homo sapiens*        (b) *Rattus rattus*
  - (c) *Mangifera indica*    (d) *Columbo livia*

#### II. Fill in the blanks.

1. \_\_\_\_\_ in 1623, introduced the binomial nomenclature.
2. Species is the \_\_\_\_\_ unit of classification.
3. \_\_\_\_\_ are non- green and non- photosynthetic in nature.
4. The binomial name of onion is \_\_\_\_\_
5. Carolus Linnaeus is known as the Father of \_\_\_\_\_

#### III. True (or) False. If false write the correct answer.

1. Classification helps to know the origin and evolution of an organism.
2. Fishes are aquatic vertebrates.
3. In the year 1979, Five kingdom classification was proposed.
4. True nucleus is seen in prokaryotic cell.
5. Animal cells have cell wall.

#### IV. Match the following.

1. Monera            –        Moulds
2. Protista            –        Bacteria
3. Fungi              –        Neem
4. Plantae            –        Butter fly
5. Animalia          –        Euglena



### V. Assertion and Reason Questions

1. **Assertion:** Binomial name is the universal name and contains two names.

**Reason :** It was first introduced by Carolus Linnaeus

- Assertion is correct, Reasoning is correct
  - Assertion is correct, Reasoning is incorrect
  - Assertion is incorrect Reasoning is correct
  - Assertion and Reasoning are incorrect
2. **Assertion:** Identification, assortment and grouping are essential for classification

**Reason :** These are basic steps of taxonomy

- Assertion is correct, Reasoning is correct
- Assertion is correct, Reasoning is incorrect
- Assertion is incorrect Reasoning is correct
- Assertion & Reasoning is incorrect

### VI. Give very short answer

- What is classification?
- List out the five kingdoms classification
- Define – dichotomous key
- Write two examples of Monera.

- What is binomial nomenclature?
- Write the binomial name of a) Human being b) Paddy
- Write two features of protista

### VII. Give short answer

- Write the levels of classification.
- Differentiate plantae and animalia
- Write any two merits of Five Kingdom classification.

### VIII. Give answer in Detail

- Explain about five kingdom classification
- Write short notes on – Binomial Nomenclature.
- Give an account on the classification of invertebrates with few general features and examples.

### IX.HOTS

Which kingdom has saprophytic, parasitic and symbiotic nutrition. Why?

### X. See the Diagram and write the kingdom :

Pictures of some living organisms are given below. Identify the kingdom to which each of these belong and write the kingdom name in the blanks provided.



(a) \_\_\_\_\_

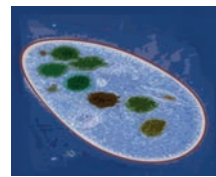

(b) \_\_\_\_\_



(c) \_\_\_\_\_



(d) \_\_\_\_\_



(e) \_\_\_\_\_





## ICT CORNER

## CLASSIFICATION

This activity enables the students to identify vertebrates And invertebrates.

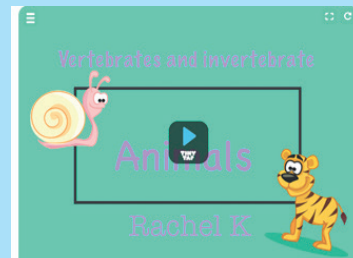

## PROCEDURE :

- Step 1:** Type the URL link given below in the browser or scan the QR code. A page opens with tinytap and “PLAY” button
- Step 2:** Click it it opens into another page
- Step 3:** The page shows animals with the words “Invertebrate or vertebrate” in a box near the animal
- Step 4:** When you click the correct option vertebrate or invertebrate it goes to next picture



Step 1



Step 2

**Classification URL:**

<https://www.tinytap.it/activities/g1fca/play/vertebrates-and-invertebrates>

\*Pictures are indicative only

\*If browser requires, allow Flash Player or Java Script to load the page.



B351\_7\_SCIENCE\_EM

# Unit 6

## Digital Painting



### Learning Objectives

After learning this lesson, the students will be able to

- ❖ know how to draw a picture through the software Tux Paint
- ❖ explore their creative thinking
- ❖ learn arithmetic calculations through the software Tux Math



In this chapter, the students will learn to use the software Tux Paint and Tux Math.

### What is Tux Paint?

Tux Paint is a free drawing program designed for young children. It has a simple, easy-to-use interface, fun sound effects, and an encouraging cartoon mascot which helps to guide children as they use the program.

Choose a Tool from the options on the left side of the screen. Then, make choices from the right side of the screen. Directions are provided at the bottom of the screen.

### Title Screen

When Tux Paint first loads, a title/credits screen will appear.



Once loading is complete, press a key or click on the mouse to continue. (Or, after about 30 seconds, the title screen will go away automatically.)

### Main Screen

The main screen is divided into following sections:

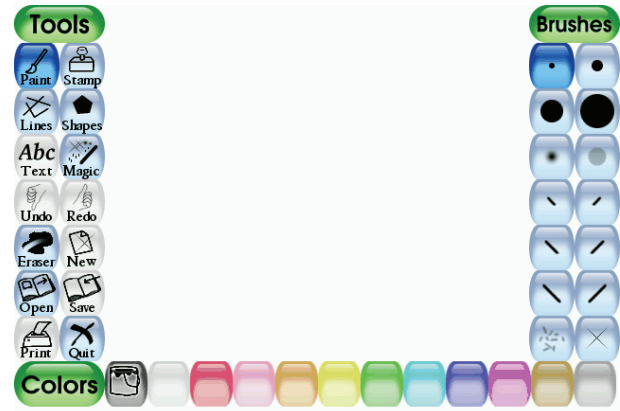

#### Left Side: Toolbar

This toolbar has the control options to draw and to edit images.

#### Middle: Drawing Canvas

This is the largest part of the screen dedicated to draw and edit images.

#### Right Side: Selector

When a tool is selected from the left side tool bar, the right side bar will display the options associated with the specific tool. (E.g.- When the line tool is selected, the right side bar shows the various lines available. When the shape tool is selected, different shape options can be seen on the right side.)

#### Lower: Colors

A palette of available colors are shown near the bottom of the screen.

#### Bottom: Help Area

At the very bottom of the screen, Tux, the Linux Penguin, provides tips and other information while you draw.

#### Tools Icons



The Paint Brush tool lets you draw freehand, using various brushes (chosen in the Selector on the right) and colors.



The Stamp tool is like a set of rubber stamps or stickers (images).



Use the Left and Right arrows to cycle through the collections.

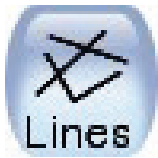

This tool is used to draw Lines.

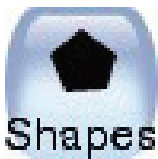

This tool lets you draw some simple filled, and un-filled shapes.



This tool is used to type texts.



Magic tool is a set of special tools, selecting one of the 'magic' effects from the selector situated in the right side. This tool provides countless number of special visual effects if it is used in various combination with other tools. This tool can be used either by clicking or by dragging the effect directly on to the image to apply it.



This tool appears similar to the Paint Brush, but it is used to erase the picture.



This tool is used to cancel a command given earlier.



This tool is used to reverse the action of Undo.



Clicking the "New" button will start a new drawing.



This tool is used to open an existing file.



This tool is used to save your current picture.



This tool is used to print your current picture.



This tool is used to close Tux Paint window.

### Shortcut Keys

Tool Name	Keyboard Shortcut Key
New	Ctrl+N
Open	Ctrl+O
Save	Ctrl + S
Print	Ctrl+P
Quit	Esc
Undo	Ctrl + Z
Redo	Ctrl+Y

### Tux Math

Tux Math is an open source arcade – style video game for learning arithmetic. The main goal is to make learning effective and fun.

### Titlle Screen

Math Command Training Academy: choose this to go to a list of over fifty prepared lessons, starting with simple typing



of single digit numbers, and progressing to multiplication and division involving negatives and "missing number" questions (e.g. " $-17 \times ? = 119$ "). The player wins if the question list is completed successfully. Successfully completed lessons are indicated with a flashing gold star.



**Play Arcade Game:** This option can be used to select and play one of the four open-ended "arcade style" games, meaning the game gets faster and faster as long as the player can keep up, with the goal to get the highest score possible.



### The options include:

- Space Cadet - simple addition.
  - Scout - addition and subtraction to ten.
  - Ranger - addition, subtraction, multiplication and division to ten.
  - Ace - all four operations with operands to 20, including negative numbers and "missing number" type questions.
- Play Custom Game:** This option can be used to play a game based on the config file in the player's home directory.
- More Options -** These options have "Demo" mode as well as credits and project information.
- ### Keys
- Use the [UP] and [DOWN] arrow keys to select what you wish to do, and then press [ENTER / RETURN / SPACEBAR]. Or, use the mouse to click the menu item.
  - Pressing [ESCAPE] will quit the program.



## Evaluation

### I. Choose the correct answer.

- Tux paint software is used to.....
  - Paint
  - Program
  - Scan
  - PDF
- Which toolbar is used for drawing and editing controls in tux paint software?
  - Left Side: Toolbar
  - Right side : Toolbar
  - Middle : Tool bar
  - Bottom : Tool bar
- What is the shortcut key for undo option?
  - Ctrl + Z
  - Ctrl + R
  - Ctrl + Y
  - Ctrl + N



4. Tux Math software helps in learning the

- \_\_\_\_\_
- Painting
  - Arithmetic
  - Programming
  - Graphics

5. In Tux Math, Space cadet option is used for .....

- Simple addition
- Division
- Drawing
- Multiplication

### Answer the following Questions

- What is Tux Paint ?
- What is the use of Text Tool ?
- What is the Shortcut key for Save option?
- What is Tux Math?
- What is the use of Ranger ?



Animal Cell	–	விலங்கு செல்
Battery	–	மின்கல அடுக்கு
Binomial	–	இருசொல் பெயர்
Boiling	–	கொதித்தல்
Cell	–	மின்கலன்
Conventional current	–	மரபுமின்னோட்டம்
Conductors	–	கடத்திகள்
Conductivity	–	கடத்துத்திறன்
Corals	–	பவளங்கள்
Classification	–	வகைப்பாடு
Chloroplast	–	பசுங்கணிகம்
Chromoplast	–	வண்ணக்கணிகம்
Cell wall	–	செல் சுவர்
Contraction	–	சுருங்குதல்
Condensation	–	ஆவி சுருங்குதல்
Crystallization	–	படிகமாக்கல்
Curdling	–	பால் உறைந்து தயிராதல்
Diaphragm	–	உதரவிதானம்
Dry cell	–	உலர்மின்கலன்
Dicotyledons	–	இரு வித்திலைத் தாவரங்கள்
Electric current	–	மின்னோட்டம்
Electrical circuit	–	மின்சுற்று
Endoplasmic reticulum	–	எண்டோபிளாச வலைப்பின்னல்
Expension	–	விரிவடைதல்
Fuse	–	மின்உருகி
Flame cells	–	சுடர் செல்கள்
Freezing	–	உறைதல்
Fermentation	–	நொதித்தல்
Green gland	–	பச்சை சுரப்பி
Heating effect	–	வெப்பவிளைவு

Insulator	–	காப்பான்கள்
Identification	–	இனங்காணல்
Invertebrates	–	முதுகெலும்பற்றவை
Leucoplast	–	வெளிர்கணிகம்
Magnetic effect	–	மின்காந்தவிளைவு
Monocotyledons	–	ஒரு வித்திலைத் தாவரங்கள்
Malpighian tubules	–	மல்பீஜியன் நுண் குழல்கள்
Microscope	–	நுண்ணோக்கி
Malleability	–	தகடாகும் தன்மை
Million	–	பத்து லட்சம்
Nephridia	–	நெஃப்ரீடியா
Nucleus	–	உட்கரு
Non – periodic change	–	கால ஒழுங்கற்ற மாற்றம்
Oyster	–	முத்துசிப்பி (கிளிஞ்சல்)
Oviparous	–	முட்டையிடுபவை
Organelle	–	நுண் உறுப்பு
Parallel circuit	–	பக்கஇணைப்பு
Parental care	–	பெற்றோர் பாதுகாப்பு
Plant Cell	–	தாவர செல்
Plastids	–	கணிகங்கள்
Plasmodesmata	–	செல்களின் இணைப்புச் சவ்வு
Periodic change	–	கால ஒழுங்கு மாற்றம்
Resistivity	–	மின்தடை
Rusting	–	துருப்பிடித்தல்
Series circuit	–	தொடர்இணைப்பு
Short circuit	–	குறுக்குசுற்று
Specific resistance	–	தன்மின்தடை
Solenoid	–	கம்பிச்சுருள்
Spicules	–	முட்கள்
Stem cell	–	மூலச்செல்
Taxonomy	–	வகைப்பாட்டியல்
UniCellular organisms	–	ஒரு செல் உயிரினங்கள்
Viviparous	–	குட்டிஈனுபவை
Vernacular Name	–	வட்டார பெயர்
Vertebrates	–	முதுகெலும்புள்ளவை
Viscosity	–	பாகுத்தன்மை
Vapourization	–	ஆவியாதல்
Water vascular system	–	நீர்க்குழல் மண்டலம்

## Authors List - VII Science

### Advisory Committee & Chairperson

**Dr. T.V. Venkateswaran**  
Scientist, DST, Vigyanaprasar,  
New Delhi.

**Dr. Mazher Sulthana**  
Professor & Head (Rtd.),  
P.G. Department of Zoology,  
Presidency College, Chennai.

### Reviewers

**Dr. V. Sivamadavi**  
Associate Professor,  
Bharathi Women's College, Chennai.

**Dr.G.Ramesh**  
Assistant Professor in chemistry  
Dr.Ambadkar Govt.Arts College  
Vyasarpadi, Chennai.

**Dr. G. Rajalakshmi**  
Assistant Professor,  
Department of Botany,  
Bharathi Women's College, Chennai.

### Content Readers

**Dr. S. Shameem**  
Deputy Director,  
SCERT, Chennai.

### ICT Coordinators

**N. Kalpana,**  
Municipal Higher Secondary School,  
Kumar Nagar, Tirupur District.

### Art and Design Team

#### Illustration

**Charles, Pramoth, Velmurugan**

#### Layout Design

**V.S. Johnsmith  
K.Petchimuthu  
R.Sagaya arasu**

#### Info Graph

**V. Srinivasan**  
Valasaravakkam, Chennai.

#### Wrapper Design

**Kathir Arumugan**

#### QC

**Manohar Radhakrishnan**

#### Co-ordination

**Ramesh munisamy**

#### Typing

**M. Sathya**  
New Perunkalathoor.

### Experts & Coordinators

**D. Prabakaran**  
Assistant Professor,  
SCERT, Chennai.

**S. Rajesh**  
B.T. Asst. GHSS, Vanganoor,  
Thiruvallur.

### Authors

**D. Perumal Raj**  
BT Asst.,  
PUMS, Manickamangalam, Valaingaiman Block, Thiruvallur.

**M. Mohanapriya**  
PGT. Asst., GHSS, Koradachery, Thiruvallur Dt.

**M. Jayanthi**  
PG Asst, GHSS. Rampakkam, Villupuram.

**N. Ramesh Babu**  
BT Asst., PUMS, Attanthangal, Sholavaram, Thiruvallur Dt.

**Dr. N. Vidhyageetha**  
Lecturer - DIET Aduthurai, Thanjavur.

**M. Ananthan**  
BT Asst., GHS, Servaikaranpatti, Dindigul.

**S. Shyamala**  
BT Asst., Govt. Adi- dravidar Welfare High School, Pulianthope,  
Chennai.

**N. Manikandan**  
BT Asst., GHS, Rasingapuram, Theni.

**N. Balusamy**  
HM (Retd.), Corporation Hr. Sec. School, Peelamedu,  
Coimbatore.

**M. Tamilarasi**  
PGT (Retd.), St. Joseph GHSS, Vadugarpet, Lalgudi, Trichy.

**S. Surenthiran**  
Computer Instructor, Govt Higher Secondary School,  
Mathavalayam, Kanniyakumari Dt.

### QR Code Management Team

**R. Jaganathan**  
S.G.T. (SPOC)  
PUMS Ganesapuram - Polur, Thiruvannamalai Dist.

**A. Devi Jesintha,**  
B.T. Asst.,  
Government High School, N.M. Kovil, Vellore.

**V. Padmavathi**  
B.T. Asst., GHS, Vetriyur, Ariyalur.